

orion®

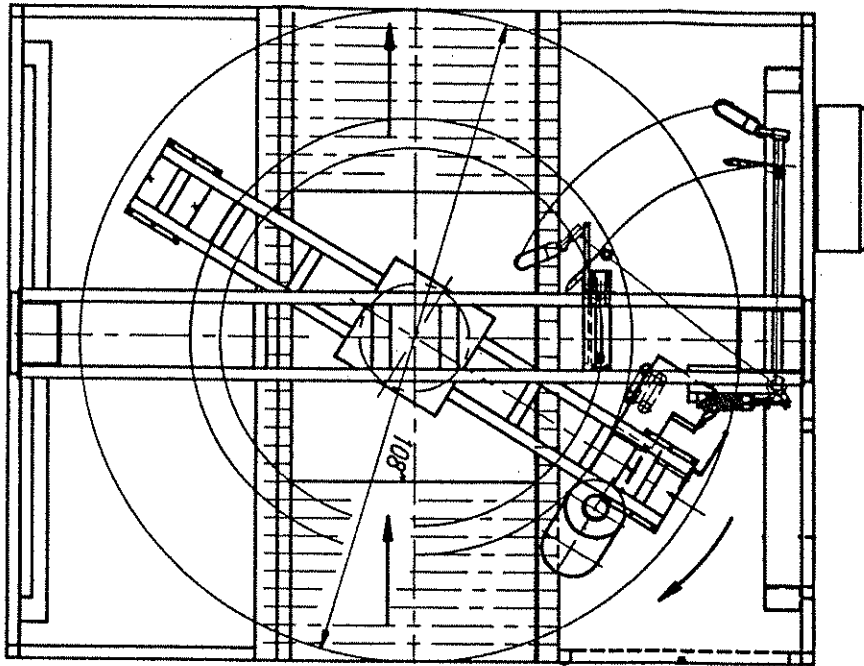

STRETCHWRAPPERS

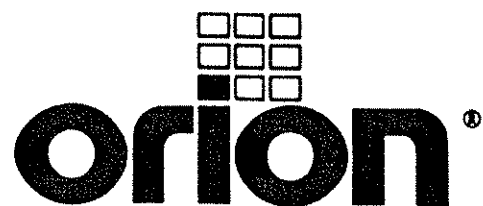

INSTRUCTION MANUAL

FOR ALL INQUIRIES
PLEASE CONTACT
OUR LOCAL DISTRIBUTOR

FOR U.S. (ONLY)
1-800-333-6556

Thank you for choosing ORION stretch-wrapping equipment. It is a wise choice which will benefit your company now and in the future.

ORION uses a unique combination of functional, rugged steel structure and sophisticated control systems to offer equipment high in durability and low in maintenance requirements. Our advanced control systems mean that ORION equipment can be operated safely and efficiently without the need for special operator expertise.

Please read this manual carefully and keep it handy. Following these simple operating instructions will insure the safe and efficient performance of this machine while simple maintenance procedures will guarantee a long and productive life of the equipment.

NOTICE:

Our manual covers standard features of the machine. Certain options may not be fully covered due to their unique application.

In order to acquire more information about custom made features of your machine and to provide quicker service, the following information is required when making an inquiry:

- 1) **MODEL** 6056251
- 2) **SERIAL NUMBER**
- 3) **SUBASSEMBLY (see PART LIST)**

*H/L 66-10
Prog. Version 1.3
Dwg. # 300 957*

SAFETY:

ORION'S stretch wrappers should be operated with caution and common sense as any other industrial equipment. To prevent injury and / or electrical shock, careful operation of the machine and awareness of its many automatic functions is required.

Note: All electrical power and compressed air must be disconnected prior to performing any inspection, maintenance or repair work.

ORION PACKAGING INC.

ORION "MATRIX" SERIES MODEL L-66

6056251

Spiral Semi-Automatic Medium Heavy Duty Low Profile

Maximum Load Size	55"W x 55"L x 84"H
Weight Capacity	4,000 lbs. Dynamic, 20,000 lbs. Static
Utilities	115/1/60 20 Amp Service
Turntable	59" Diameter Structural Steel Plate Steel Cam Follower Support System Self Lubricating System with Reservoirs 3" Height Floor to Top of Turntable
Turntable Drive	0 - 14 RPM Variable Turntable Speed DC Variable Speed Drive Motor Heavy Duty Chain Drive with Tensioner Adjustable Electronic Soft Start Positive Alignment Feature
Control Features	CSA Approved, NEMA 12 Control Panel State-of-the-Art Allen Bradley Programmable Logic Control for Maximum Flexibility User Friendly Controls with Non-Proprietary Pushbuttons, and Switches Electronic Film Tension Control Adjustment on the Panel End of Cycle Film Force Release Separate Top and Bottom Wrap Count Selectors Variable Speed Film Carriage Up/Down Control Film Carriage Raise/Lower Switch (Manual) Cycle Pause On/Off Switch Photocell for Automatic Load Height Detection with On/Off Switch Turntable Jog Pushbutton Spiral Up or Up/Down Cycles
Film Delivery	20" Orion MultiStretch Power Prestretch Easy to Thread Film Carriage Electronic Film Tension Control Adjustment on the Panel Full Authority Film Dancer Bar with Variable Speed Output Heavy Duty ANSI Chain & Sprocket Ratio Control Maximum Available Pre-Stretch Ratio of 425% (Standard Setting of 245%) DC Variable Speed Drive Motor Adjustable Film Roping Bar on Chassis for Stronger Interlocking of Load and Pallet
Film Carriage Elevator Drive	Heavy Duty ANSI Chain Carriage Lift DC Variable Speed Drive Motor Structural "H" Beam Guidance Ultra-High Molecular Weight Carriage Guidance System
Structural Features	100% Structural Steel Construction Throughout Non-Proprietary, Locally Obtainable Components Throughout Easy Access to All Components Open Mechanical Design for Ease of Maintenance Forklift Portable Base Design Structural Steel "H" Beam Mast
Estimated Shipping Weight	1,650 lbs.

MACHINE UNLOADING INSPECTION & INSTALLATION

UNLOADING

Machine can be easily unloaded and transported by a forklift with a minimum capacity of 2500 lbs.

1. Carefully insert the forks into the lifting tubes to the maximum possible depth. Depending on the model, a forklift access may be either at the turntable end of the machine frame, the tower end or both. In case of the mongoose machine or the conveyor, enter the forks under the frame.
2. Lift the machine (or other part of system) only to the necessary height to move it with no bouncing or friction on the floor.
 - 2a. On the mongoose machines use the brackets welded on the top part of the machine.
3. Sit the machine down assuring uniform contact with the floor which is necessary to ensure correct and smooth operation.
 - 3a. Mongoose type machines (M66, M67) have to be attached on the bracket or on the stand (collapsible or anchored to the floor). The M55 has it's own supporting frame which allows the machine to stand independently.

INSPECTION

1. Remove all packing and supporting additions - these may include the blocks under the carriage and the restraining bar over the table.

NOTE: when removing the stretchwrap film covering the machine, care must be taken not to cut any of the electrical wires and rubber covering on the multistretch rollers.

2. Perform a visual inspection of the electrical and mechanical parts for loosened joints and / or broken connections. Any suspected shipping damage must be reported immediately to the freight carrier.

Items that are vulnerable to damage and must be inspected are as follows:

- motors and transmissions
- junction boxes
- electrical conduits
- proximity and limit switches
- photocells

3. Check under the turntable (H - series models only) to ensure that there is no crippling of the movable parts i.e. casters, center axle or drive assembly.

4. Verify the following:

- turntable or rotary arm drive system to confirm that the reducer to drive the chain is snug and properly aligned
- verify the wires tight conduits for crushed sections or loose fittings
- verify the carriage to be sure that it is correctly aligned with the tower and verify the tension on the lift chain
- verify all the dials and knobs on the control panel for smooth action.

MACHINE INSTALLATION

After the visual inspection has been completed the electrical power and the compressed air may be connected as specified on the diagrams supplied with the machine.

An electrical diagram is provided with each machine in the envelope attached to the panel box.

ASSEMBLY PROCEDURE

The structural frames of the machine have to be installed on a levelled floor. Locate the main wrapper section into its final position, keeping the tower assembly* away from any traffic.

The wrapper mainframe section must be bolted to the floor by the 1/2" concrete floor anchors (leg & shield or expandable type).

Conveyor sections (where applicable) have to be positioned, levelled** and bolted to the floor. Any wiring which has been disconnected to facilitate transport is marked with a number located on the junction box to which the wiring must be reconnected. It allows identification of the proper position of the infeed and outfeed conveyor sections. Any wire run that appears too short or long may indicate that the position of the mechanical components is incorrect. Verify the status of all assemblies before proceeding.

CAUTION: improper placement and alignment of the conveyor section(s) and/or electric photocells may lead to equipment malfunction and damage.

* The tower deviation from vertical must not exceed 1/4" on the distance of 10 feet (angle: 0 degrees 6').

** In the case of the conveyors, the roller deviation from the horizontal must not exceed 1/16 "on the distance 52" (angle: 0 degrees 4').

CONTROL PANEL

In the case of the free standing panel (console) place it adjacent to the system and anchor firmly to the floor. Connect the liquid tide (rigid conduit) to the main junction box located on the wrapper main frame next to the tower (or tower home position in case of mongoose). The wires must be matched properly on both sides.

In order to facilitate access and manipulation, the control panel can be mounted in two positions:

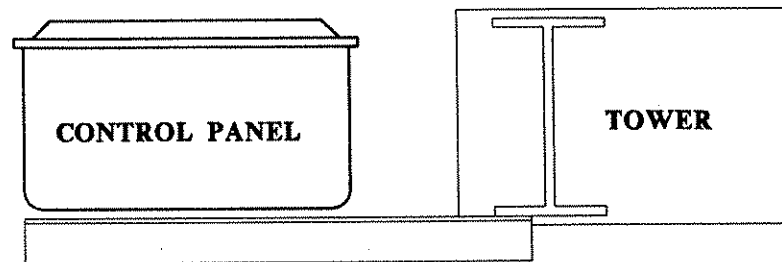

1. On the angle brackets aligned to the tower.

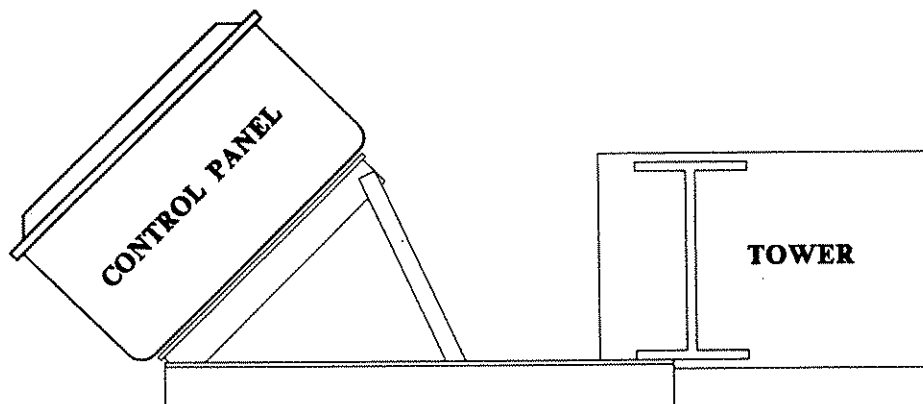

2. With the position bar (installed between upper angles), control panel can be rotated forward/to the side. (additional screw is attached to the tower's foot)

CONTROL PANEL MOUNT TWO POSITIONS

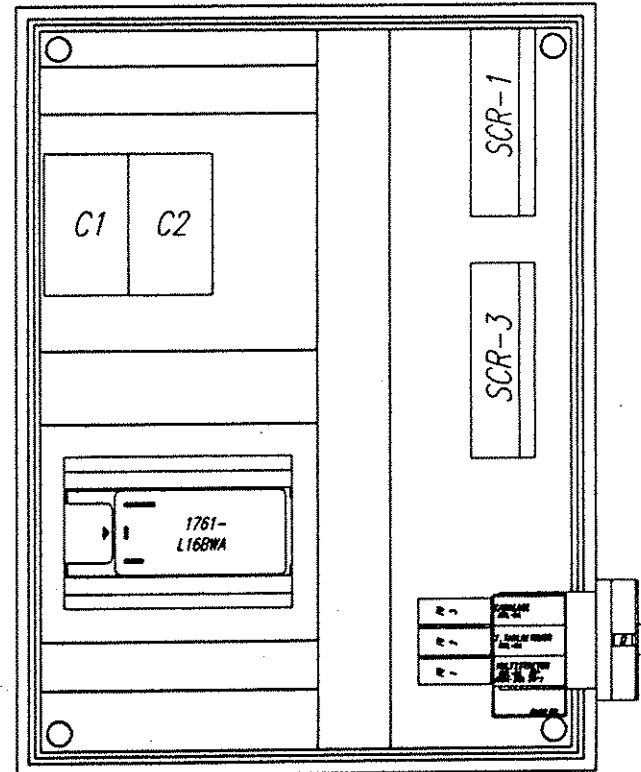
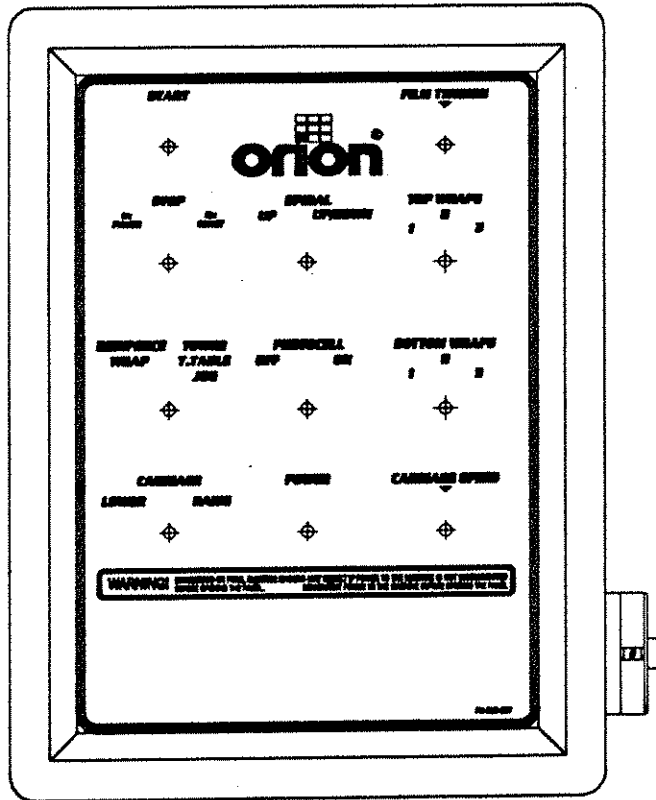

HL66-10 PANEL LAYOUT
16 x 12 x 06

NOTE: SCR-2 (168-A) IS LOCATED ON ENCLOSURE DOOR.

 ORION PACKAGING INC. 2270 INDUSTRIEL BOUL. LAMÉ QUÉBEC, CANADA, H7S 1P9 TEL: (514) 667-9769	ORION PACKAGING INC.		SCALE:	
	2270 INDUSTRIEL BOUL. LAMÉ, QUÉ. CANADA, H7S 1P9 TEL: (514) 667-9769 FAX: (514) 667-6320 APPR. BY: J.B.S. DESIGN BY: J. ALDINGER		1:2	
	TITLE:			REV:
	H/L66-10			1
SIZE:	DOCUMENT NO:	300 893/PL		
C	JOB # STD	1		
DATE:	SEPT-16-1995	SHEET	1 OF 1	
FILENAME:	H66-10PL	BASE		

START

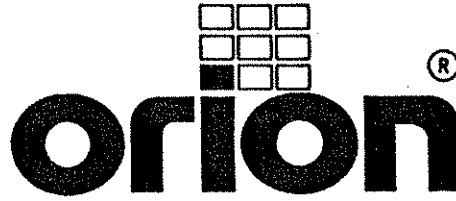
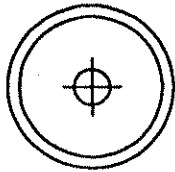

FILM TENSION

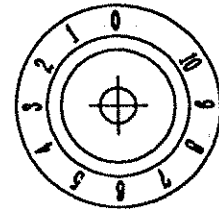

STOP

**1x
PAUSE**

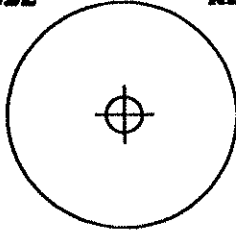

**2x
RESET**

**SPIRAL
UP UP/DOWN**

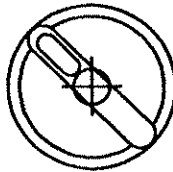

TOP WRAPS

1 2 3

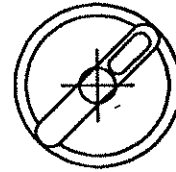

REINFORCE WRAP TOWER T.TABLE JOG

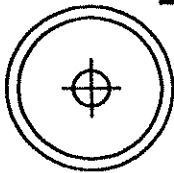

PHOTOCELL OFF ON

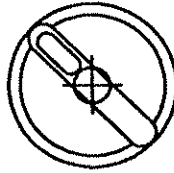

BOTTOM WRAPS

1 2 3

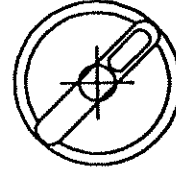

CARRIAGE

LOWER

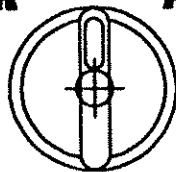

RAISE

POWER

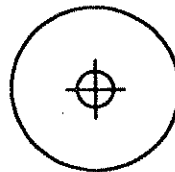

CARRIAGE SPEED

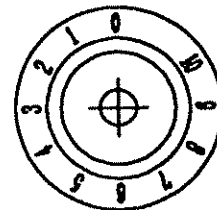

WARNING!

DANGEROUS OR FATAL ELECTRIC SHOCKS MAY RESULT IF POWER TO THE MACHINE IS NOT DISCONNECTED BEFORE OPENING THE PANEL. DISCONNECT POWER TO THE MACHINE BEFORE OPENING THE PANEL.

CARRIAGE SPEED

The carriage speed potentiometer control can be used to control the amount of overlap the film will have during the wrap. The potentiometer has settings from 0 to 10, the higher settings being the fastest. High settings mean less film overlap because of faster carriage speed and low settings mean more film overlap because of lower carriage speed.

TOP WRAPS 1,2,3...9

Three position switch controls the number of wraps that may be applied on the top of the load. The machine is preset RANGE # 1 (top wraps: 1 or 2 or 3). To change the values of wrap see *TOP & BOTTOM WRAP COUNTS CHANGE*.

BOTTOM WRAPS 1,2,3,...9

Three position switch controls the number of wraps that may be applied on the bottom of the load. The machine is preset with RANGE # 1 (bottom wraps: 1 or 2 or 3) which may be applied. To change the values of wrap see *TOP & BOTTOM WRAP COUNTS CHANGE*.

TOP & BOTTOM WRAP COUNTS CHANGE

The Top & Bottom Wrap Selector Switches have three (3) ranges of wrap counts and operate independently of each other.

Range #1	Wrap values of 1-2-3
Range #2	Wrap values of 4-5-6
Range #3	Wrap values of 7-8-9

For the selection of any of these ranges for top and bottom wraps please do as follows:

Before proceeding ensure that machine is in MANUAL, STANDBY MODE (machine is powered on and all machine manual functions are enabled)

1. Press the STOP (Red) Button
2. Set the Top and Bottom wrap count selector switch to the position corresponding with the desired count range.:
1= Range #1
2= Range #2
3= Range #3
3. Press the START (Green) pushbuttons and maintain for approximately 12 seconds.
4. Pull the STOP (Red) push-button out.
5. Perform standard machine reset procedure by double push-pull operation of the red mushroom stop button.

At this point machine is ready and new preset values are loaded

CYCLE CONTROLS

The control panel layout is custom designed for each particular installation, however, common standard controls have been employed.

CAUTION: before proceeding be familiar with the EMERGENCY button and all functions, switches and pushbuttons.

POWER SWITCH

The Power Switch has two settings:

ON - connects a power source to the machine (voltage depends on the machine type - see electrical diagram provided with the machine).

OFF - disconnects the power source.

START AND STOP SWITCHES (EMERGENCY STOP)

The **START** switch is used to start the cycle once the load is on the turntable (or under the rotary arm). The cycle may be stopped at anytime by pressing the **STOP** button.

NOTICE: In case of emergency, use the **STOP** button which interrupts all the machine electrical circuits (except multistretch drive). If the **STOP** pushbutton is pressed in the middle of the cycle, the carriage and turntable may be returned to their home position by using the jog buttons before restarting the cycle.

SPIRAL WRAP SWITCH

The **SPIRAL WRAP** switch has two positions:

UP - in this position the cycle will end after completing the specified number of top wraps, therefore, the machine will only wrap the load once, going up.

UP/DOWN - in this position the cycle will be completed after the load is wrapped in both the up and down directions.

NOTE: TOP WRAP FIRST (OPTIONAL)

The carriage raises faster at the beginning of the cycle to wrap the top of the load (see electrical diagram provided with the machine).

CARRIAGE CONTROL SWITCH

The CARRIAGE CONTROL switch is a three position switch with the following settings:

RAISE - raises the carriage until the top limit switch on the tower is activated.

LOWER - lowers the carriage until the bottom limit switch on the tower is attained.

The switch is normally positioned in the middle where the carriage remains stationary. Turning the switch to the RAISE or LOWER will activate the carriage to move in its respective direction.

TURNTABLE (ROTARY TOWER) JOG

The turntable (rotary tower) jog switch is a pushbutton which will rotate the turntable (rotary arm) in a clockwise direction (as viewed from the top) when the switch is held depressed. When the switch is released the turntable (rotary tower) will stop. The switch is inoperative during the wrap cycle.

PHOTOCELL SWITCH

The photocell switch has two settings:

ON - when turned ON, the photocell instructs the carriage to stop and begin the top wraps sequence once the top of the load is reached. The carriage will always stop at the top of the load regardless of its height. The photoswitch position on the track can be adjusted in order to make the carriage pass the top of the load and overlap the top.

OFF - when turned OFF, the photocell is inoperative and the carriage will stop when the top limit switch has been activated.

FILM TENSION

Film tension may be adjusted using the film tension control knob. It has a range of tension from 0 to 10 (0 to 4 the low range, 4 to 8 the most usefull range for most of the films used by our customers, 8 to 10 as a very high range which may break some films).

NOTE: Lighter loads may require lower tension settings then heavier loads.

Film tension is controlled through the dancer bar system. Occasionally the feed back proximity sensor may need some adjustment. Adjustment of feed back is shown on drawing # 001

Adjustment instructions:

- remove the carriage cover
- unbolt the two nuts holding the proximity switch -item # 1
- turn the proximity switch - item # 2 until the moment when the motor starts to turn (or hums)
- tighten on the nuts securing the proximity switch.

NOTE: The condition in which the motor hums but does not turn must be maintained even after all elements are tightened. If not, the adjustment procedure must be repeated.

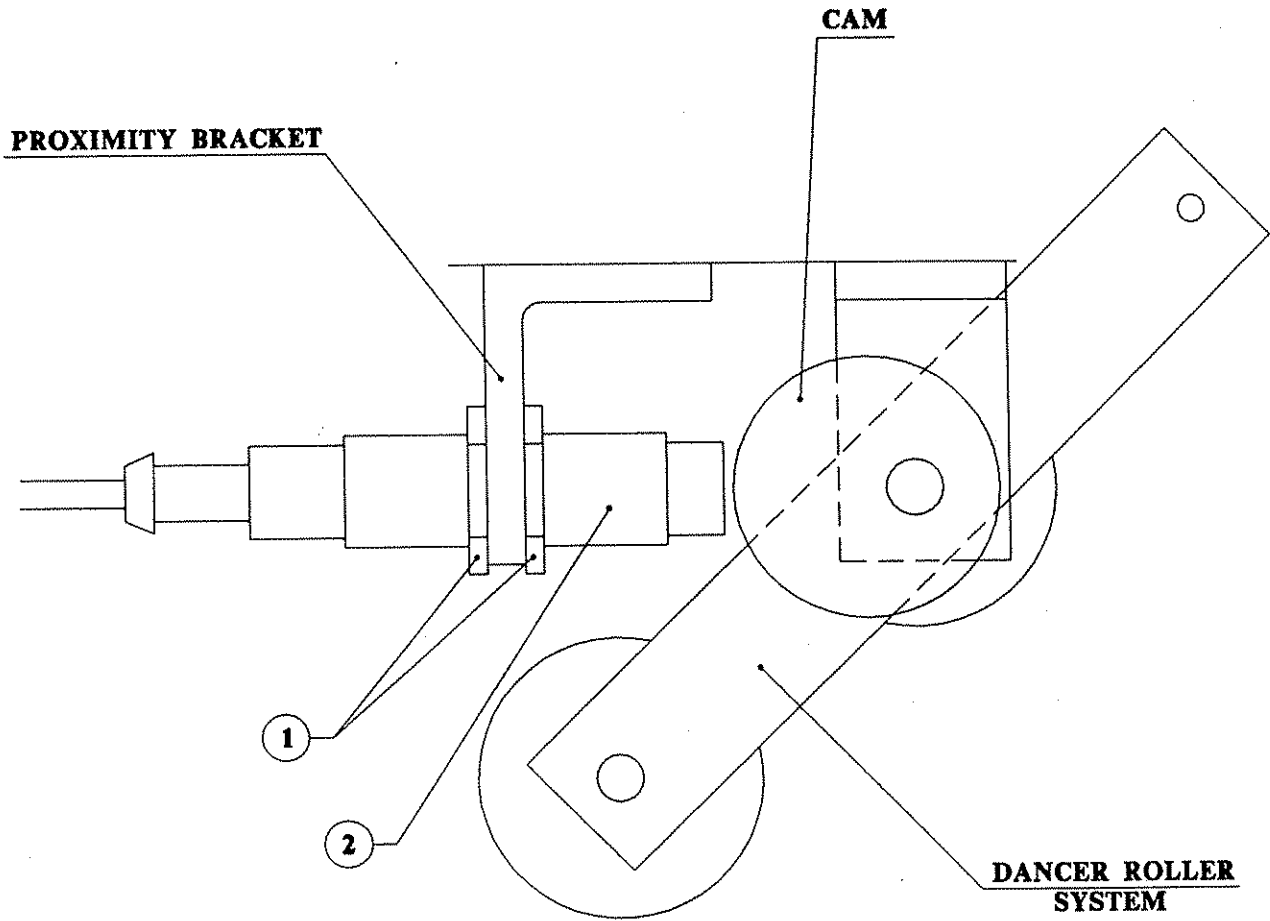

PROXIMITY SENSOR FEED BACK ADJUSTMENT

DWG. # 001

TO LOAD THE FILM....

The film roll can be loaded on the mandrel of the carriage from either end of the roll. When using tacky film, please verify that the inward tacky surface of the film is inward on the load.

1. Disconnect power (turn off power switch).
2. Put the roll of film on the mandrel and press down to insure penetration of spikes into the cardboard center of the film roll.
3. In the case of automatic machines, install the film cap on top of the roll to prevent upward movement.
4. Introduce the roping end of the film between the shafts of all rollers (as shown on the dwg.) and pull to pass it around all three rollers (pressure roller and both rubber rollers).
5. Pass the film between the two dancer (aluminium) rollers (in certain applications the film has to be passed around one or two additional position aluminium rollers).
6. When the film feeding is completed - turn the power switch ON
7. Peel off the first few winds of the film (multistretch will run due to displacement of the dancer roller) and fix the film end onto the load or into the clamp mechanism (if machine is fully automatic).

The system is now ready to begin the first wrapping cycle.
Proceed to page titled **SYSTEM START UP**.

SYSTEM START-UP

Notice: It is advisable to test-run the equipment with several pallet loads before make the attempt to wrap with film. Please position a worker at the EMERGENCY STOP push button.

Start up of the machine (system) may determine the need for the adjustment of:

- pallet sensor eyes (automatic systems only)
- load height stop photoswitch (on the carriage)
- conveyor acceleration/deceleration
- turntable speed & jog speed
- turntable speed acceleration/deceleration
- turntable home position (rotary tower home position)
- film tail treatment devices (automatic systems).

MACHINE WRAPPING TEST

Before the test procedure adjust the wrapping cycle parameters i.e. top wraps, bottom wraps, height photocell on/off, film tension, carriage speed (those two parameters may be adjusted during the wrapping cycle).

When there is no photocell, verify the top limit switch position.

MACHINE MAINTENANCE

REDUCER OIL CHANGE

On the reducing transmission, after the first week all external cap screws and plugs should be checked for tightness. It is recommended to change the oil every six months or 25000 hours of operation, whichever ever comes first. When adding oil, the transmission should never be filled above the oil level mark indicated, because leakage and overheating may occur. Below is a list of the type of lubricant that should be used:

Manufacturer	Lubricant
American Oil CO.	American Cyl Oil no:196-L
Cities Service Oil Co.	Citgo Cyl.Oil 100-5
Gulf Oil Corp.	Gulf Senate 155
Mobil Oil Corp.	Mobil 600 W Suerr Cyl.Oil
Philips Oil Co.	Andes S 180
Texaco Inc.	624+650T Cyl.Oil
Shell Oil Co.	Velvata Oil J82
Union Oil Of Cal.	Red Line Worm Gear Lube 140

MOTOR MAINTENANCE

An occasional inspection of the brushes should be made in order to establish a wear rate. Replacement brushes should be installed before old brushes wear to 9/16" long, measured on the long side. After replacing brushes run the motor near rated speed for at least 1/2 hour with no load to seat the new brushes.

Failure to properly seat the new brushes may cause commutator damage and rapid wear of the new brushes. If the commutator becomes rough, scored or out of shape, a competent motor shop should disassemble the motor and resurface the commutator. With every third brush change, have a competent motor shop resurface the commutator and blow the carbon dust out of the motor.

CHAIN MAINTENANCE

To clean the chain, wipe it with an oily cloth every month. If the environment is very dusty or damp, it may be necessary to clean it more often.

With time the chain will tend to stretch. A loose elevator and turntable (rotary arm) chain should be tightened at the chain tensioner, or by moving the reducer on the mounting plate.

CAM FOLLOWER MAINTENANCE

The cam followers behind the carriage have deep grease pockets and do not need frequent relubrication. The portion of the tower on which the cam followers run, should be cleaned and regreased every 300 hours of operation. If the machine operates in a dusty or corrosive environment the tower should be relubricated more often.

**SEMI-AUTOMATIC
STANDARD ASSEMBLY
PART LIST**

Note :

- * Quantity listed in order of part number**
- ** The names given to the parts are generic**

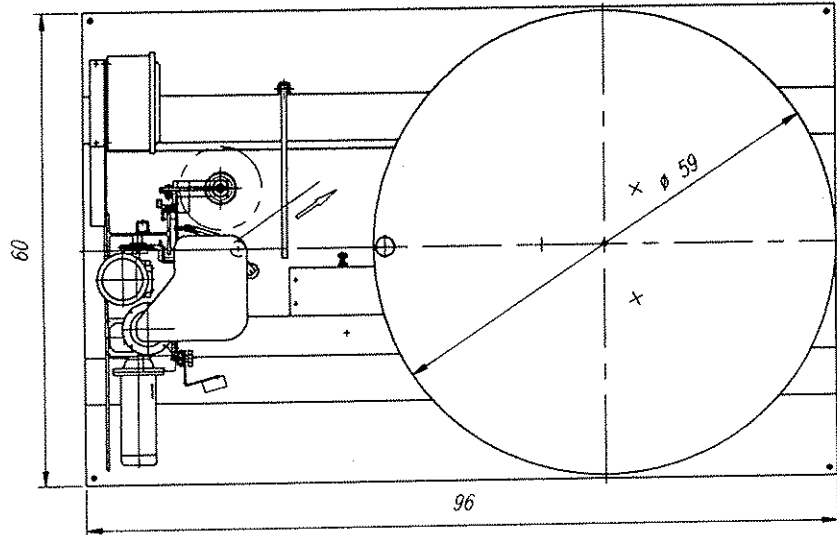
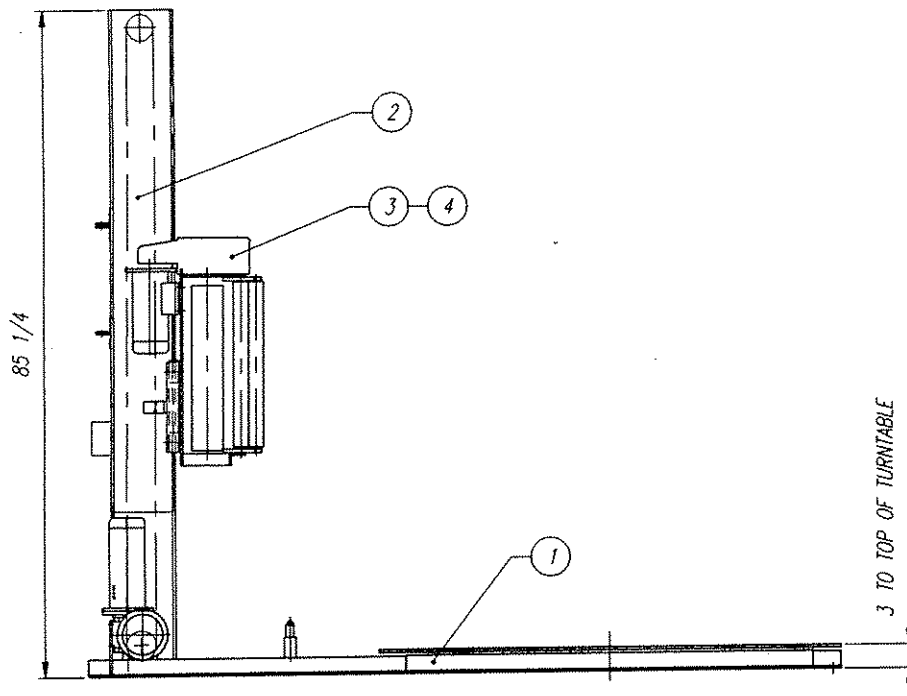

TOP VIEW

REQ'D - 1 PCE

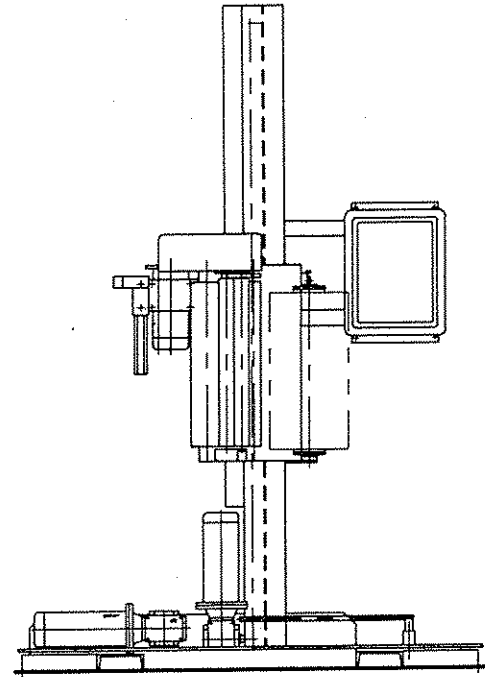

TOTAL WEIGHT : 1325 (1350) LBS

4	30" FILM CARRIAGE ASSEMBLY	C	409706	1	142
3	20" FILM CARRIAGE ASSEMBLY	C	409704	1	117
2	TOWER ASSEMBLY - W8 x 18	C	409007	1	-
1	L-66/10 BASE ASSEMBLY	C	408908	1	1162

No.	DESCRIPTION	DWG SIZE	PART No.	Q'ty	WEIGHT
-----	-------------	----------	----------	------	--------

REMARKS: -

REMARKS: -

LOW PROFILE L-66/10 - LAYOUT

<p>ORION PACKAGING INC. 2270 INDUSTRIEL LAVAL QUEBEC, CANADA, H7S 1P9 TEL.: (514) 667-9769</p>	DATE:	AUG-18-1995	SCALE:	1 : 16	
	DRAWN BY:	ROGER F.	MACHINE TYPE:	L66/10	
	CHECKED BY:		DRAWING SIZE:	B	
	ASSEMBLY DWG:	LAYOUT	JOB No.:	STD	DRAWING No.

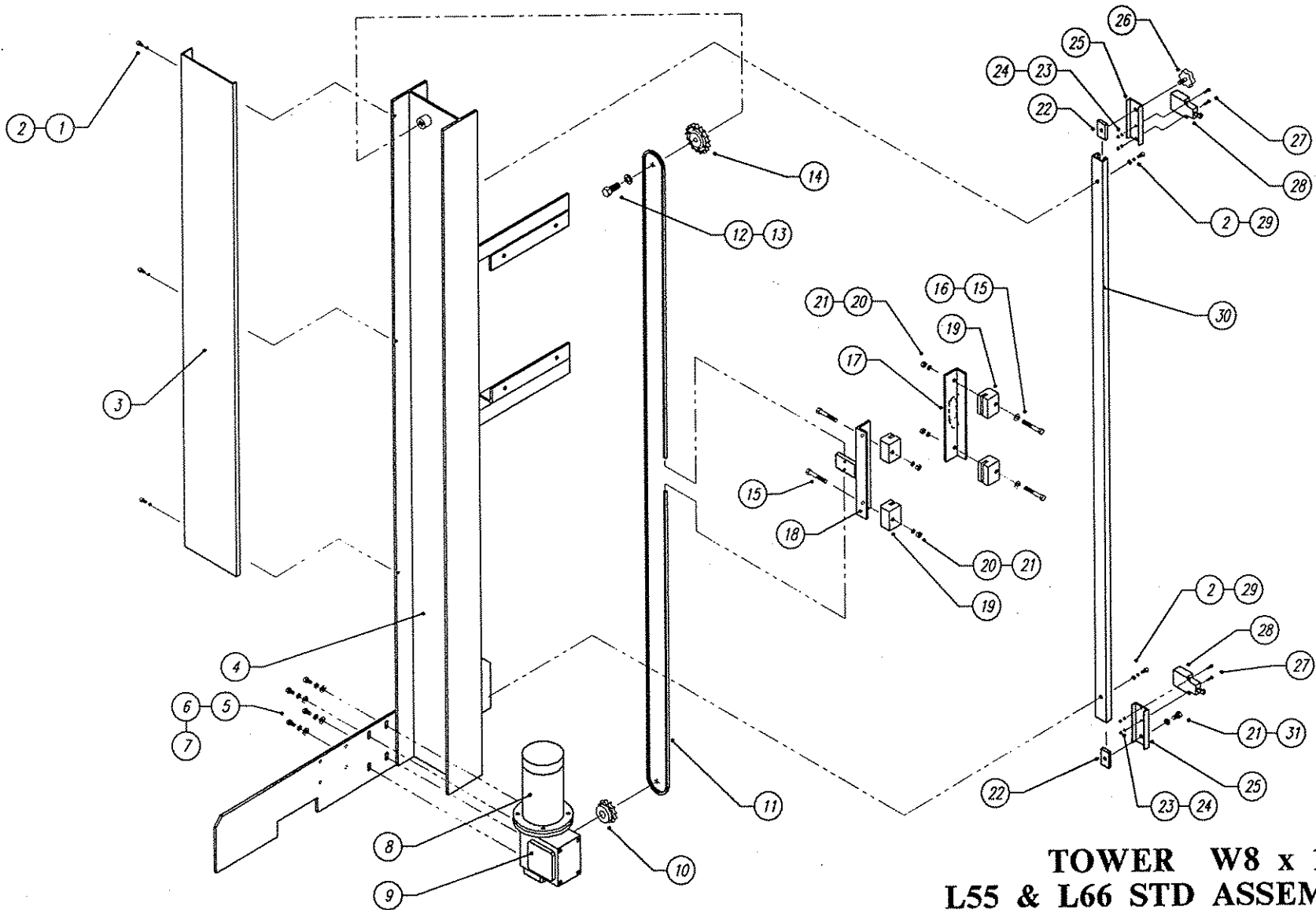

**TOWER W8 x 18
L55 & L66 STD ASSEMBLY**

UPDATED MAY-17-95

409166

TOWER W8 x 18 for L55, 66/10**STD ASSEMBLY PART LIST**

Dwg. # 409166 updated Sep-28-95

NO.	PART #	DESCRIPTION	QTY
1.	012049	PAN PHILLSCREW	3
2.	011393	SPRING WASHER	5
3.	408187	TOWER CHAIN GUARD	1
4.	408911	TOWER W8x18	1
5.	012723	HEX HEAD SCREW	4
6.	012724	SPRING WASHER	4
7.	012725	FLAT WASHER	4
8.	010036	ELECTR. MOTOR	1
9.	010344	REDUCER	1
10.	010235	SPROCKET	1
11.	010009	CHAIN	1
12.	010329	HEX HEAD SCREW	1
13.	012721	SPRING WASHER	1
14.	010008	IDLER SPROCKET	1
15.	010401	HEX HEAD SCREW	4
16.	010948	FLAT WASHER	2
17.	408190	SLIDE BLOCK ALIGNING ANGLE	1
18.	408869	FILM CARRIAGE ATTACHMENT	1
19.	408193	SLIDE BLOCK	4
20.	011128	HEX NUT	4
21.	011390	SPRING WASHER	4
22.	220518	CHANNEL GUIDE	2
23.	012726	HEX NUT	4
24.	012743	SPRING WASHER	4
25.	260816	LIMIT SWITCH HOLDER	2
26.	010092	KNOB	1
27.	012690	PAN PHILL SCREW	4
28.	010123	LIMIT SWITCH	2
29.	010257	SOCKET HEAD CAP SCREW	2
30.	409047	LIMIT SWITCH CHANNEL	1
31.	012474	HEX HEAD SCREW	1

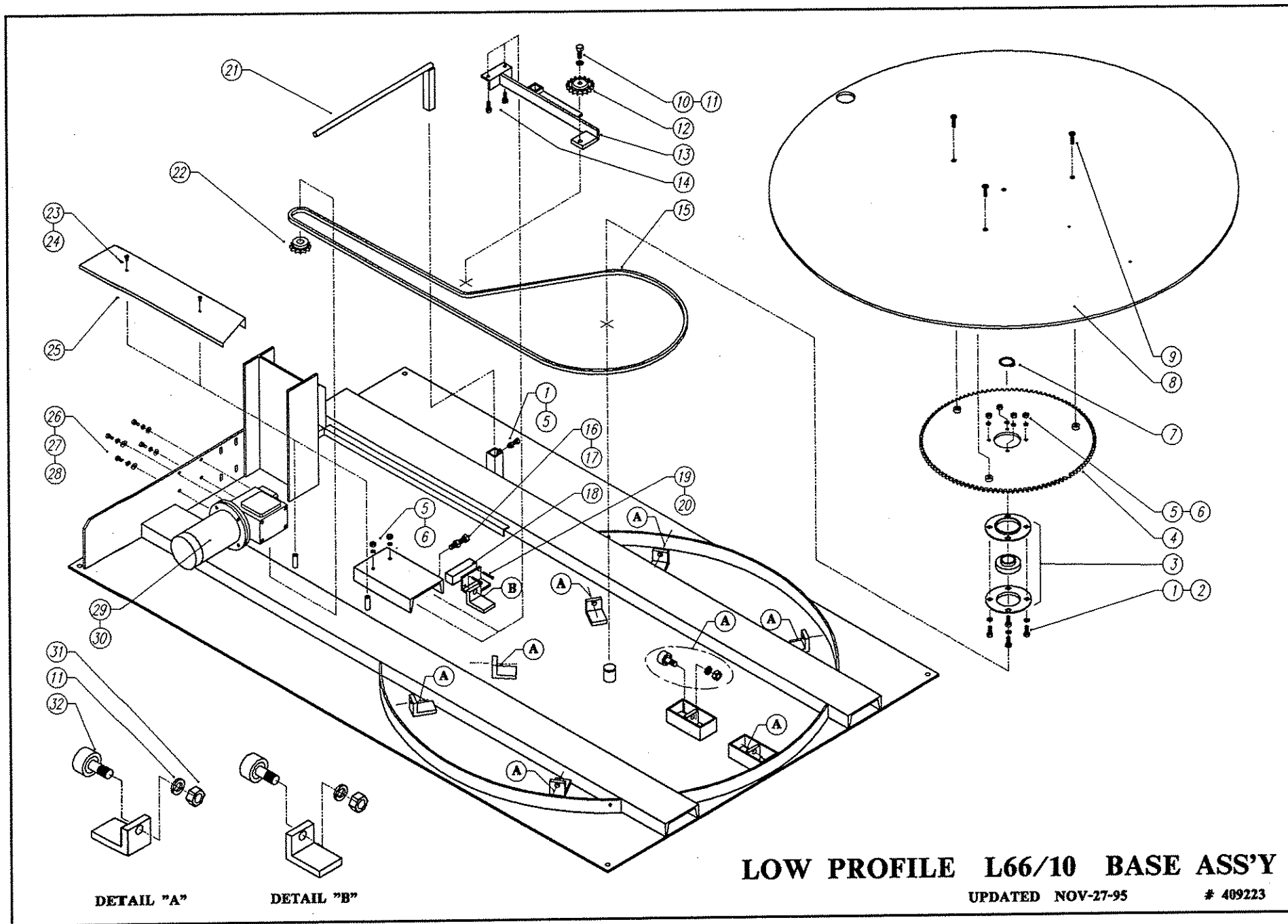

DETAIL "A"

DETAIL "B"

LOW PROFILE L66/10 BASE ASS'Y

UPDATED NOV-27-95

409223

LOW PROFILE L66/10 BASE ASS'Y - PART LIST

409223 updated Nov-27-95

NO.	PART #.	DESCRIPTION	Q-TY
1.	012406	HEX HEAD SCREW	5
2.	010948	FLAT WASHER	4
3.	010007	CENTRAL BEARING UNIT	1
4.	407783	TURNTABLE SPROCKET	1
5.	011128	HEX NUT	6
6.	011390	SPRING WASHER	4
7.	013326	EXTERNAL RETAINING RING	1
8.	407782	TURNTABLE DISK	1
9.	013842	FLAT SOCKET CAP SCREW	3
10.	010329	HEX HEAD SCREW	1
11.	012721	SPRING WASHER	10
12.	010008	IDLER SPROCKET	1
13.	260681	CHAIN TENSIONER ARM	1
14.	010293	HEX HEAD SCREW	2
15.	010009	CHAIN	1
16.	010408	CHAIN TENSION SCREW	1
17.	011266	HEX NUT	1
18.	010739	PROXIMITY SWITCH	1
19.	012858	PAN PHILL SCREW	2
20.	012726	HEX NUT	2
21.	403521	ROPING BAR	1
22.	010343	SPROCKET	1
23.	012049	PAN PHILL SCREW	2
24.	011393	SPRING WASHER	2
25.	408910	CHAIN GUARD	1
26.	010291	HEX HEAD SCREW	4
27.	012724	SPRING WASHER	4
28.	012725	FLAT WASHER	4
29.	010036	ELECTR. MOTOR	1
30.	010093	REDUCER	1
31.	011322	HEX NUT	9
32.	012531	CAM FOLLOWER	9

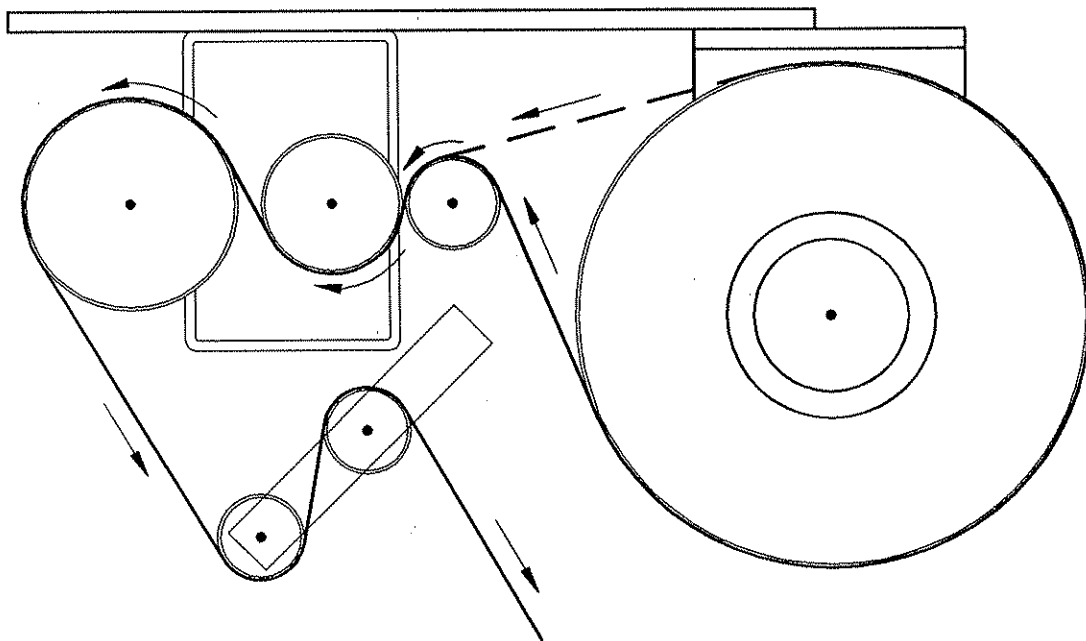

WARNING:

DISCONNECT POWER BEFORE FEEDING FILM

**FILM FEEDING PATTERN
FOR STANDARD CARRIAGE**

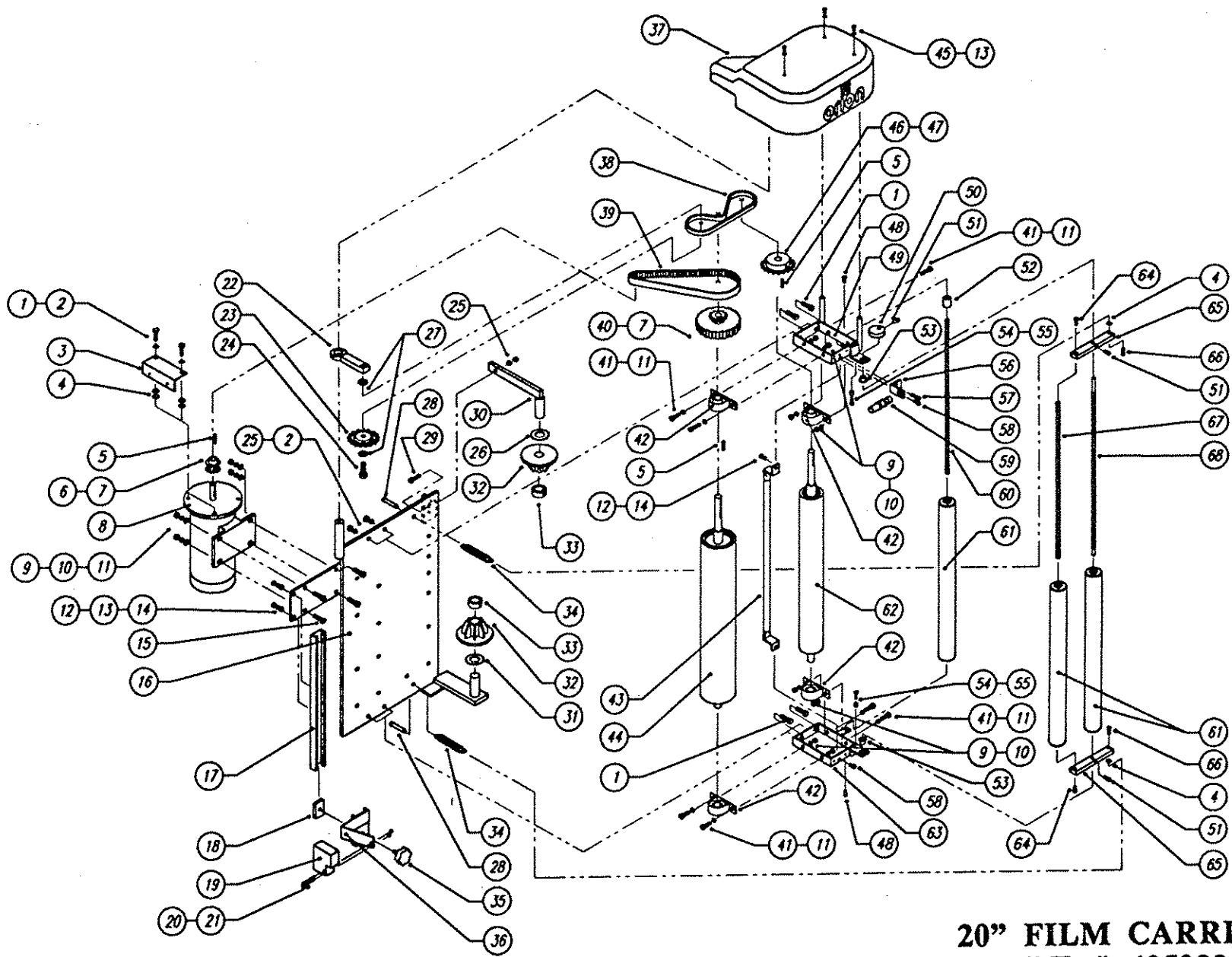

20" FILM CARRIAGE STD
PART # 405032 - ASS'Y
 UPDATED MAY-09-94 # 484354

**20" FILM CARRIAGE STD
PART # 405032 ASS'Y - PART LIST**

Updated Sep-28-95

Dwg. # 404354

NO.	ORION PART #	DESCRIPTION	Q-TY
1.	010293	HEX HEAD SCREW	6
2.	011390	SPRING WASHER	6
3.	250162	JUNCTION BOX BRACKET	1
4.	010948	FLAT WASHER	4
5.	010295	SQ. KEY	3
6.	011283	TIMING BELT PULLEY	1
7.	012800	SET SCREW	2
8.	010036	ELECTR. MOTOR	1
9.	012751	HEX NUT	12
10.	012724	SPRING WASHER	12
11.	012725	FLAT WASHER	12
12.	012689	HEX NUT	3
13.	011393	SPRING WASHER	5
14.	012221	FLAT WASHER	3
15.	012757	HEX HEAD SCREW	4
16.	408948	BACK PLATE F/20" FILM	1
17.	404184	PHOTOCELL CHANNEL F/20" FILM	1
18.	220518	CHANNEL GUIDE	1
19.	011495 -	PHOTOCELL	1
20.	012754	PAN PHILL SCREW	2
21.	012726	HEX NUT	2
22.	401357	CHAIN TENSIONER	1
23.	011297	IDLER SPROCKET	1
24.	012482	HEX HEAD SCREW	1
25.	011128	HEX NUT	6
26.	012323	FLAT WASHER	1
27.	012584	FLAT WASHER	2
28.	401375	CLEVIS PIN	2
29.	010322	HEX HEAD SCREW	1
30.	403802	TOP MANDREL	1

NO.	ORION PART #	DESCRIPTION	Q-TY
31.	013040	THRUST WASHER	1
32.	405855	SPOOL	2
33.	010052	COLLAR	2
34.	010047	TENSION SPRING, 40 COILS	2
or	011424	TENSION SPRING, UPPER, 50 COILS	1
	401320	TENSION SPRING, LOWER, 37 COILS	1
35.	010092	KNOB	1
36.	230721	PHOTOCELL BRACKET	1
37.	404935	FIBERGLASS COVER	1
38.	010583	CHAIN	1
39.	012685	TIMING BELT	1
40.	403494	PULLEY/SPROCKET	1
41.	010291	HEX HEAD SCREW	8
42.	010427	PILLOW BLOCK BEARING	4
43.	403449	SAFETY BAR	1
44.	402791	RUBBER ROLLER 4 1/8" DIA.	1
45.	012049	PAN PHILL SCREW	3
46.	011457	DRIVE SPROCKET, PRESTRETCH 245 %	1
47.	012805	SET SCREW	2
48.	012475	HEX HEAD SCREW	2
49.	402787	TOP BRACKET	1
50.	230648	PROXIMITY SENSOR CAM	1
51.	010257	SOCKET HEAD CAP SCREW	3
52.	402822	PLASTIC TUBE SPACER	1
53.	010058	FL.BRONZE BUSHING	2
54.	011423	SHOULDER SCREW	2
55.	010946	PLASTIC HOSE	2
56.	230647	PROXIMITY SENSOR BRACKET	1
57.	010277	HEX HEAD SCREW	1
58.	012722	HEX HEAD SCREW	2
59.	011470	PROXIMITY SENSOR	1
60.	402794	SNUB ROLLER SHAFT	1
61.	402789	ALUMINUM ROLLER	3
62.	402790	RUBBER ROLLER 2 3/4" DIA.	1

NO.	ORION PART #	DESCRIPTION	Q-TY
63.	402788	BOTTOM BRACKET	1
64.	010259	SOCKET HEAD CAP SCREW	2
65.	401358	DANCER ROLLER LEVER	2
66.	401374	CLEVIS PIN	2
67.	402792	DANCER ROLLER SHAFT	1
68.	402793	DANCER LEVER SHAFT	1

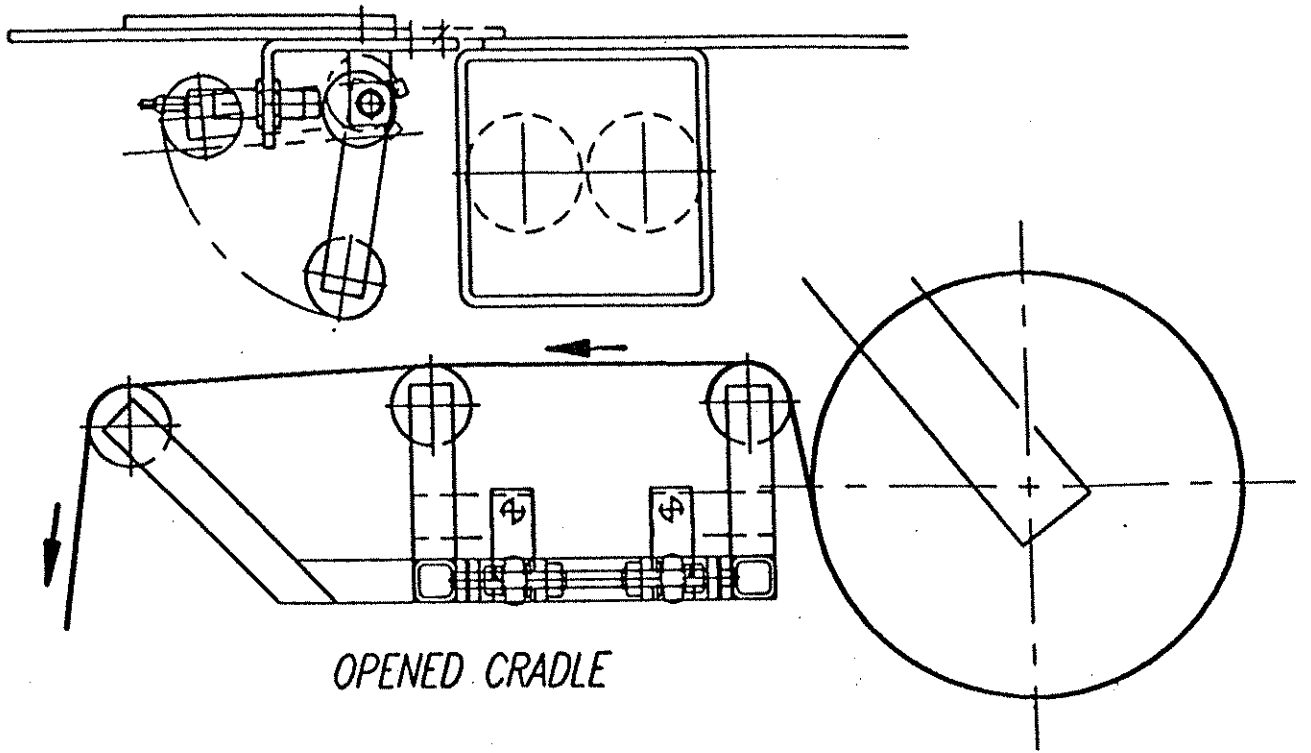

OPENED CRADLE

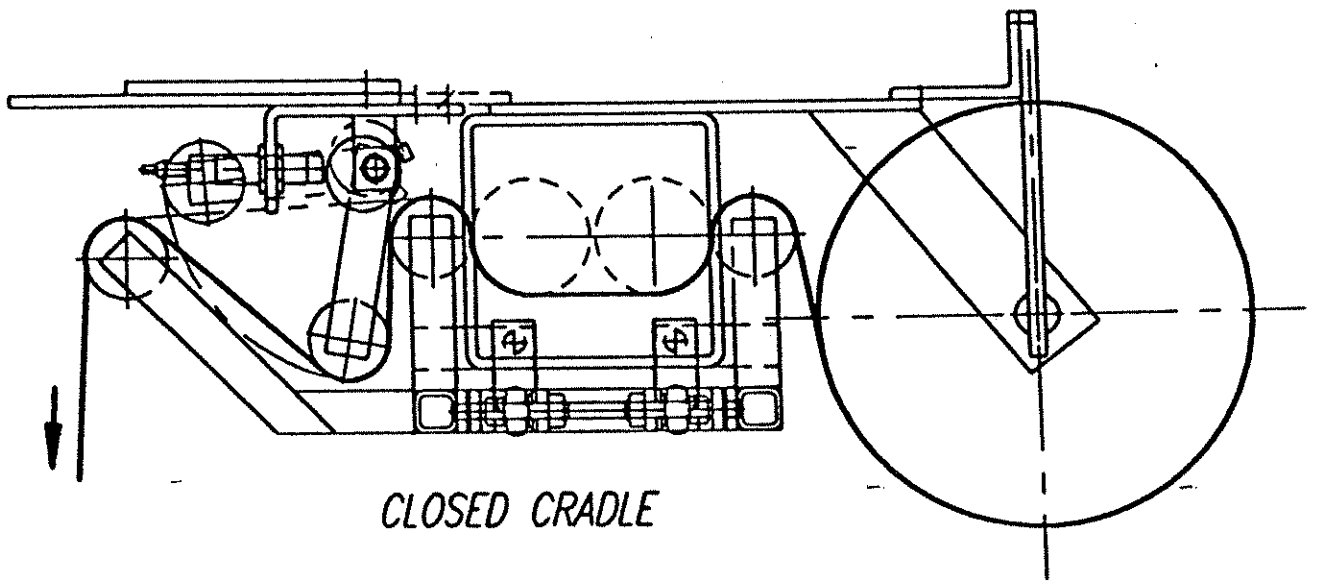

CLOSED CRADLE

FILM QUICK THREADING

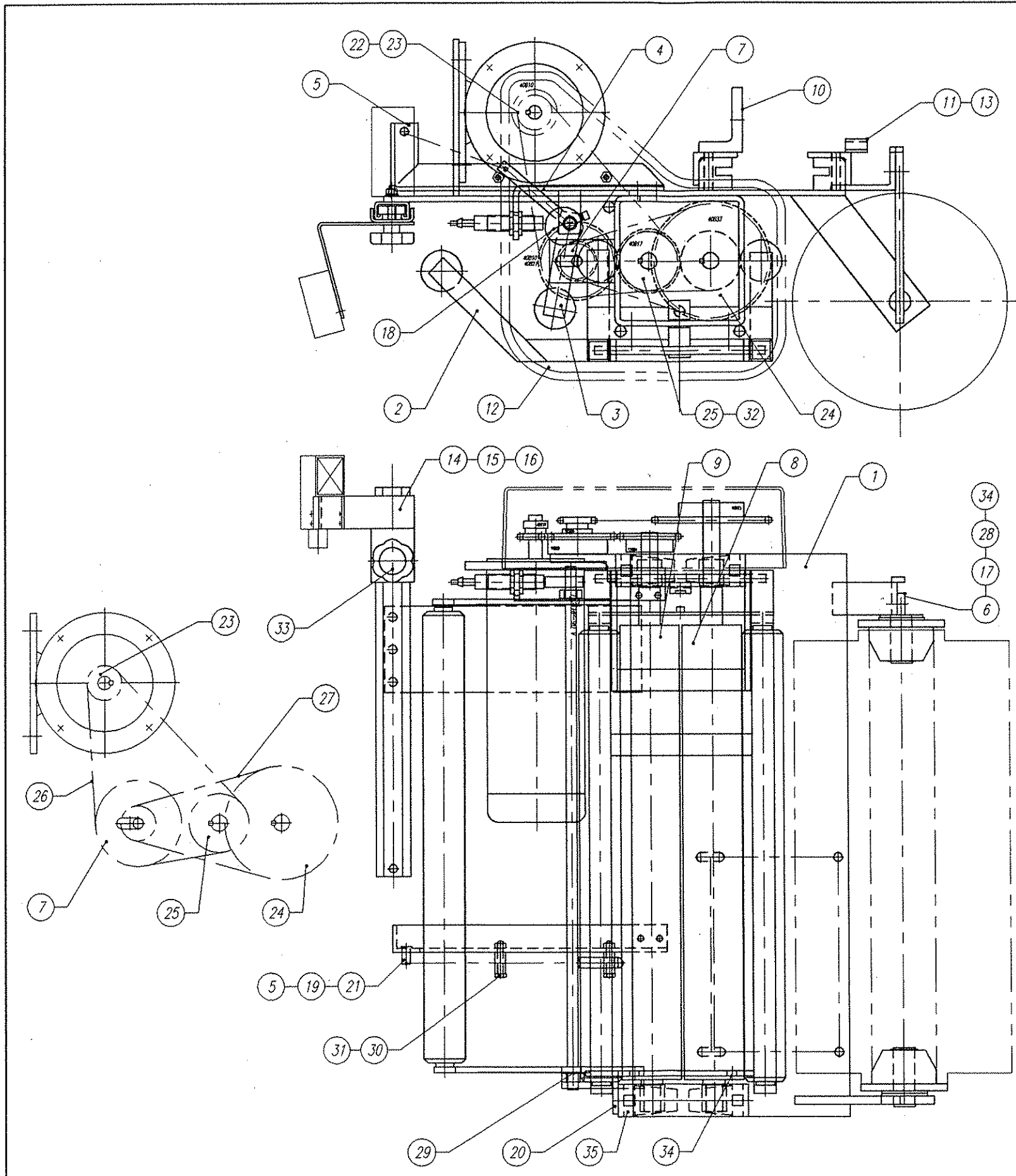

35	PILLOW BLOCK	011192	4	
34	FLAT WASHER	012323	2	
33	BLACK KNOB	010092	1	
32	SQ. KEY	010227	3	
31	HEX BOLT	012765	1	
30	PLASTIC HOSE	010946	2	
29	FL. BRONZE BUSHING	013858	1	
28	SELF SEATING RETAINING RING	013860	2	
27	CHAIN	010583	1	
26	CHAIN	010583	1	
25	SPROCKET	011452	1	
24	SPROCKET - 245 % PRESTRETCH	011462	1	
23	SPROCKET	012085	1	
22	ELECTRIC MOTOR	010036	1	
21	CLEVIS PIN	401375	1	
20	CRADLE ROLLER OPENING LOCK	A 409469	1	
19	EXTENSION SPRING	B 403118	1	
18	PROXIMITY SENSOR CAM	A 408898	1	
17	SPOOL	A 405855	2	
16	PHOTOCELL CHANNEL - 20	A 409628	1	
15	CHANNEL GUIDE	A 220518	1	
14	PHOTOCELL BRACKET	A 230721	1	
13	SLIDE BLOCK	A 408193	4	
12	FIBERGLASS COVER	B 410308	1	
11	SLIDE BLOCK ALIGNING ANGLE	A 408190	1	
10	FILM CARRIAGE ATTACHMENT	B 408869	1	
9	RUBBER ROLLER - 2 (20" FILM)	A 408641	1	
8	RUBBER ROLLER - 1 (20" FILM)	A 408640	1	
7	DOUBLE SPROCKET	A 409170	1	
6	TOP MANDREL	A 408638	1	
5	DANCER ROLLER SPRING BRACKET	A 408637	1	
4	DANCER ROLLER TOP BRACKET	A 408866	1	
3	DANCER ROLLER ASSEMBLY - 20" FILM	A 408634	1	
2	CRADLE ROLLER ASSEMBLY - 20" FILM	B 410119	1	
1	TL-BACK PLATE - 20" FILM	B 410118	1	

No.	WEIGHT	DESCRIPTION	DWG. SIZE	PART No.	Q'ty	WEIGHT
REMARKS: TREAD-LESS 20" FILM CARRIAGE, W8 x18 TOWER						
REMARKS: -						

INSTA-THREAD (20" FILM CARRIAGE)

<p>ORION PACKAGING INC. 2270 INDUSTRIEL, LAVAL QUEBEC, CANADA, H7S 1P6 TEL.: (514) 687-9769</p>	DATE:	NOV-23-1995	SCALE:	1 : 4	
	DRAWN BY:	ROGER F.	MACHINE TYPE:	H/L/10	
	CHECKED BY:		DRAWING SIZE:	C	
	ASSEMBLY DWG.:	LAYOUT	JOB No.:	STD	DRAWING No.:



DC - OUT
DC + OUT
AC2 IN
AC1 IN (NEUTRAL)

168-A CARRIAGE UP/DN
SINGLE SPEED BOARD

MULTISTRETCH 336-6/7/9 MOTOR CONTROL BOARD CALIBRATION INSTRUCTIONS

Bias: (RV3) The **RV3** pot controls the system bias.

This control injects an offset voltage that adds or subtracts from the voltage reference defined by the external tension adjustment (film tension potentiometer); this will allow extremes of adjustment to be set to levels consistent with proper operation. Typically, the bias will be used to center the operation range in the linear portion of its characteristics.

Note: This adjustment is normally factory pre-set and should not require field adjustment. For reference, the factory test procedure calls for a setting of 1.3 volts DC at the cathode of Z1 (Zener Diode) achieved by adjusting the **RV3** pot. Check for voltage between the (-IN) and the pin located next to the bias trim-pot.

Span: (RV1) The **RV1** pot controls the systems loop gain.

The system loop gain may be adjusted if the motor continues to be energized when the dancer roller is unloaded and at rest. With the machine stopped, the pot should be adjusted to ensure that the motor is de-energized in this condition, and so that a light pull on the free end of the film causes the film to feed freely. Counter clockwise (CCW) adjustment of this pot will increase the response time, in effect softening the motor tension response plus decreasing the maximum motor speed attainable. Clockwise (CW) adjustment will decrease the response time, in effect sharpening the motor response time plus increasing the maximum motor speed attainable.

Current Limit: (RV4) The **RV4** pot controls the torque (amperage) that the 336 board will allow to the motor.

To protect the unit against damage should the motor stall, jam, or current demands exceed its rating, a current limiting circuit is included which keeps motor current at a safe level regardless of motor load or input from the Hall effect proximity switch.

This pot is factory pre-set to suit ½ HP motors. Should changes be required in the field, proceed as follows: Monitor the motor current. Turn the current limit **RV4** to minimum (full CCW). Stall the motor. Advance the pot slowly until the desired current is achieved. This should not exceed 125% of the motor nameplate rating. Do not stall the motor for more than a few seconds, or damage may occur.

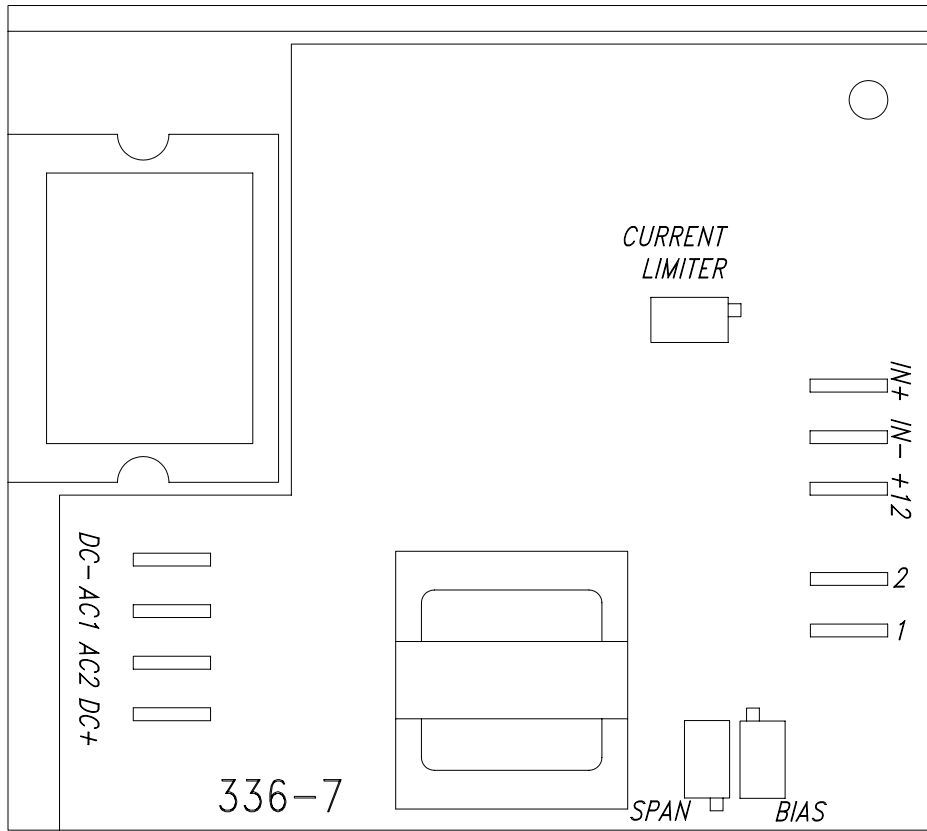

DC+: ARMATURE CONTROL

AC1: AC INPUT

AC2: AC INPUT

DC-: ARMATURE CONTROL

POTENTIOMETER

SPAN: HALL EFFECT SENSITIVITY CONTROL

BIAS: SYSTEM BIAS (FACTORY SET)

TRIP: END OR BROKEN FILM SENSING CIRCUITRY.
TRIP LEVEL (FACTORY SET)

CURRENT LIMITER: (FACTORY SET)

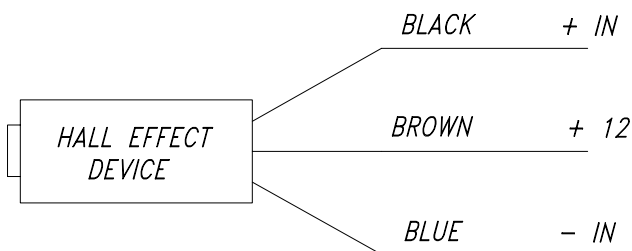

*FILM TENSION ADJUSTMENT
REMOTE POTENTIOMETER*

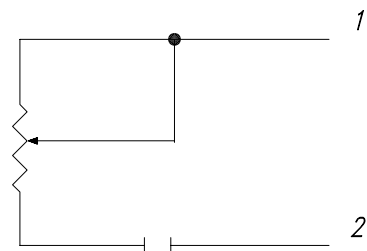

*tension on/off
relay*

336-7

MULTISTRETCH BOARD

TURNTABLE & TOWER MOTOR CONTROL BOARD ADJUSTMENTS

66 & 55 SERIES EQUIPMENT (850M & 850DM Board)

INTRODUCTION

The 850M and 850 DM Motor Control Boards are DC/SCR drives that are used in 66 & 55 series Orion stretch wrapping equipment. The following calibration instructions apply to all 66 & 55 series turntable and rotary tower type machinery, but it will be important to note specific reference to your particular Orion model for best calibration results.

The 850M and 850DM boards feature two selectable pre-set speeds (1 & 2), and four potentiometers (marked 1,2,A and D).

The instructions are in the suggested order of adjustment, and intended to be made after installation of the board in the control enclosure. Please refer to the attached sketch of the board for identification of the adjustment points.

INSTALLATION

This unit is equipped with an aluminum chassis, which serves as a heatsink. This should be oriented with the printed circuit board in a vertical plane for optimum convection cooling.

Connectors are to .250" quick-disconnect terminals. Standard units require 120 VAC supply. AC line attaches to terminals **AC1**, **AC2**. Motor Armature attaches to terminals **DC+**, **DC-**. The standard unit is suitable for permanent magnet shunt style DC motors with 90 V armature rating.

ADJUSTMENTS

Acceleration: (RV3) The pot marked **A** is the control for the acceleration or electronic soft start feature.

For an initial setting, turn the **A** pot fully counter-clockwise (CCW) until a faint “clicking” sound is heard, then approximately 2 turns (or revolutions) clockwise (CW). CW adjustment of this potentiometer softens the start and lengthens the time required for the turntable/tower to reach its preset speed.

Speed Control: (RV1) The pot marked **1** controls the turntable/tower jog speed₁.

Simply activate the turntable/tower jog function, adjusting the jog speed (pot 1) as the turntable/tower rotates. This should be set for approximately 2 to 3 RPM. Please note that this setting should be made with a load on the turntable (turntable type models only). A CW turn increases the jog speed, while CCW decreases jog speed.

Speed Control: (RV2) The pot marked **2** is the control for the high speed₂ for the turntable/tower during the wrap cycle once acceleration is complete.

This speed can be as high as 12 RPM. However, you should note that if it is set too high, you may see chopping of the current to the turntable/tower drive motor which will cause pulsating, half-speed operation of the turntable/tower drive itself. If this is seen, please decrease the setting of pot **2**, until it is no longer in effect.

For best calibration results, it is recommended that you make this adjustment while the machine is in cycle. After starting a wrap cycle, set the film carriage speed control to the “0” (minimum) position. This will prevent the film carriage from rising and completing its cycle. Then simply adjust the high speed (pot **2**) as the turntable/tower rotates. A CW turn increases speed, a CCW turn decreases speed.

1 Speed Control 1 = Turntable/Tower Jog Speed
Selected by a 120 VAC signal applied from terminal (1) to (C)

2 Speed Control 2 = Turntable/Tower High Speed
Selected by a 120 VAC signal applied from terminal (2) to (C)

Deceleration: (RV4) The pot marked **D** is the deceleration control. Functionally, it is the opposite of acceleration, except that it is a more critical setting, in that our machine logic requires that we decelerate from speed 2 to speed 1 during the course of the final revolution of the turntable/tower before shutoff.

For an initial setting, start with the **D** pot set fully CCW. Then, cycling the machine; observe the transition to jog speed at the end of the cycle, prior to the stop of the turntable/tower at the home position. Gradually increase the **D** pot setting (CW) until the turntable/tower only jogs approximately 1/8 to 1/4 revolution before reaching home position. CW adjustment of this potentiometer quickens the stop and shortens the deceleration time required for the turntable/tower to settle to its preset jog speed. CCW softens the stop and lengthens the time required for the turntable/tower to settle to its preset jog speed.

Thus, the deceleration control is important in that if the deceleration time is too short, we will prematurely reach jog speed and jog an excessive amount of time to the home position before shutoff.

Conversely, if the deceleration time is set too long, the turntable/tower will not settle to the jog speed and thus will be going too fast to align properly and the momentum will take the turntable/tower beyond the start position. As you can imagine, any time the wrap speed is changed, you will need to make a corresponding change in the setting of the pot marked **D** (for deceleration).

Note: The 850DM requires a jumper from the **W** pin to the **CW** pin for speed 2 to operate.

TROUBLE SHOOTING & REPAIR

In most cases, repair will require parts replacement. If user intends to, and is equipped to perform repairs, spare parts are available from Orion Parts & Service.

Damage is usually visually evident on the 850M board. Replacing the obviously damaged board frequently restores operation. However, if damage is not evidently visible, swapping boards will determine if the board is at fault.

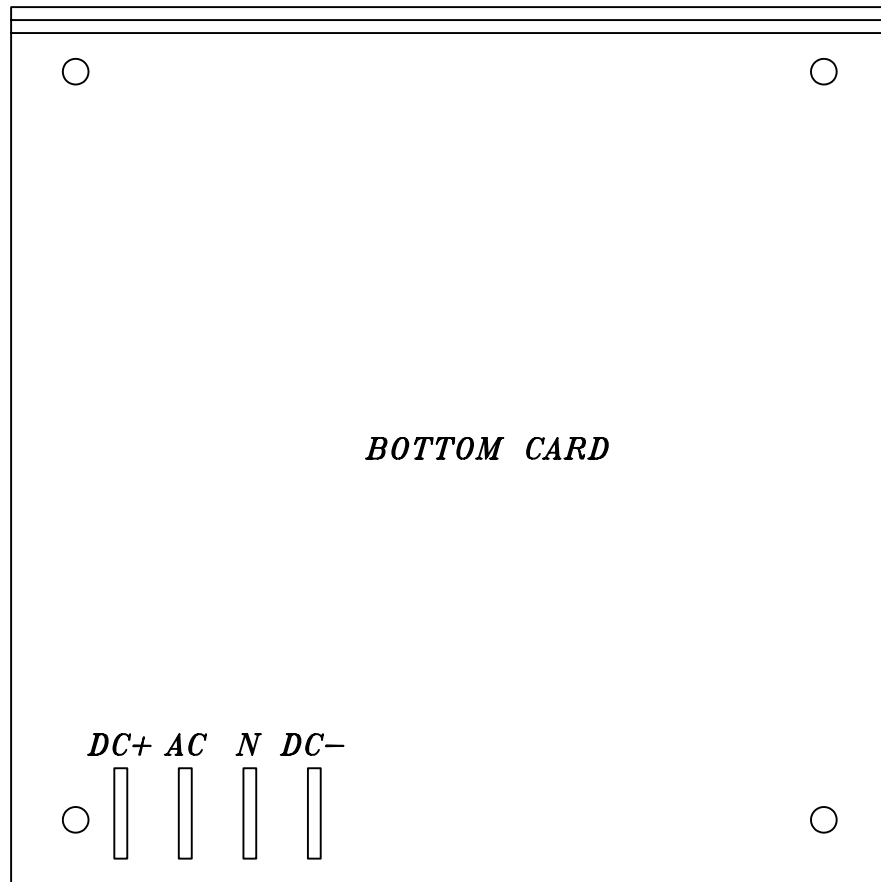

DC+ : ARMATURE CONTROL.
AC : AC INPUT - LINE.
N : AC INPUT - NEUTRAL.
DC- : ARMATURE CONTROL.

1 : CONTROL - LINE. LOW SPEED
1 : LOW SPEED ADJ.
2 : CONTROL - LINE. HIGH SPEED
2 : HIGH SPEED ADJ.
C : CONTROL - COMMON.
(REQUIRES A JUMPER TO "N")

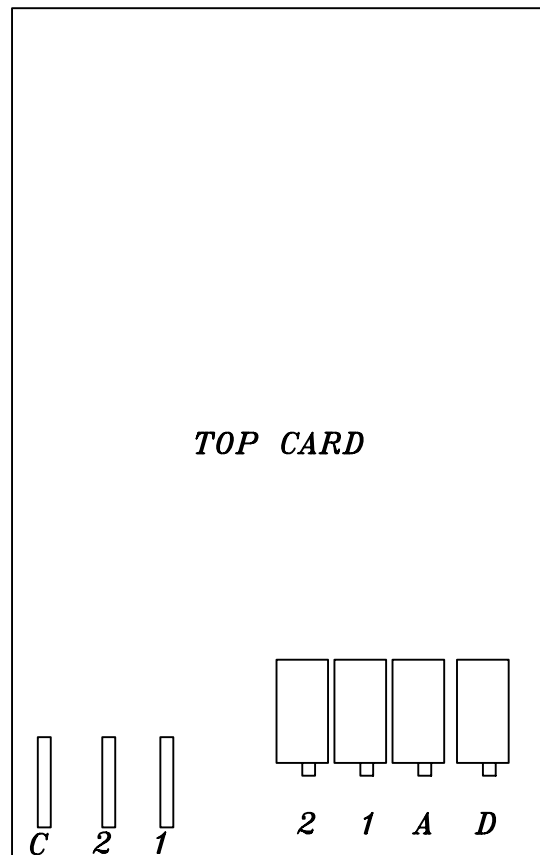

*850M TWO SPEED 120VAC/90VDC
 MOTOR CONTROL BOARD*

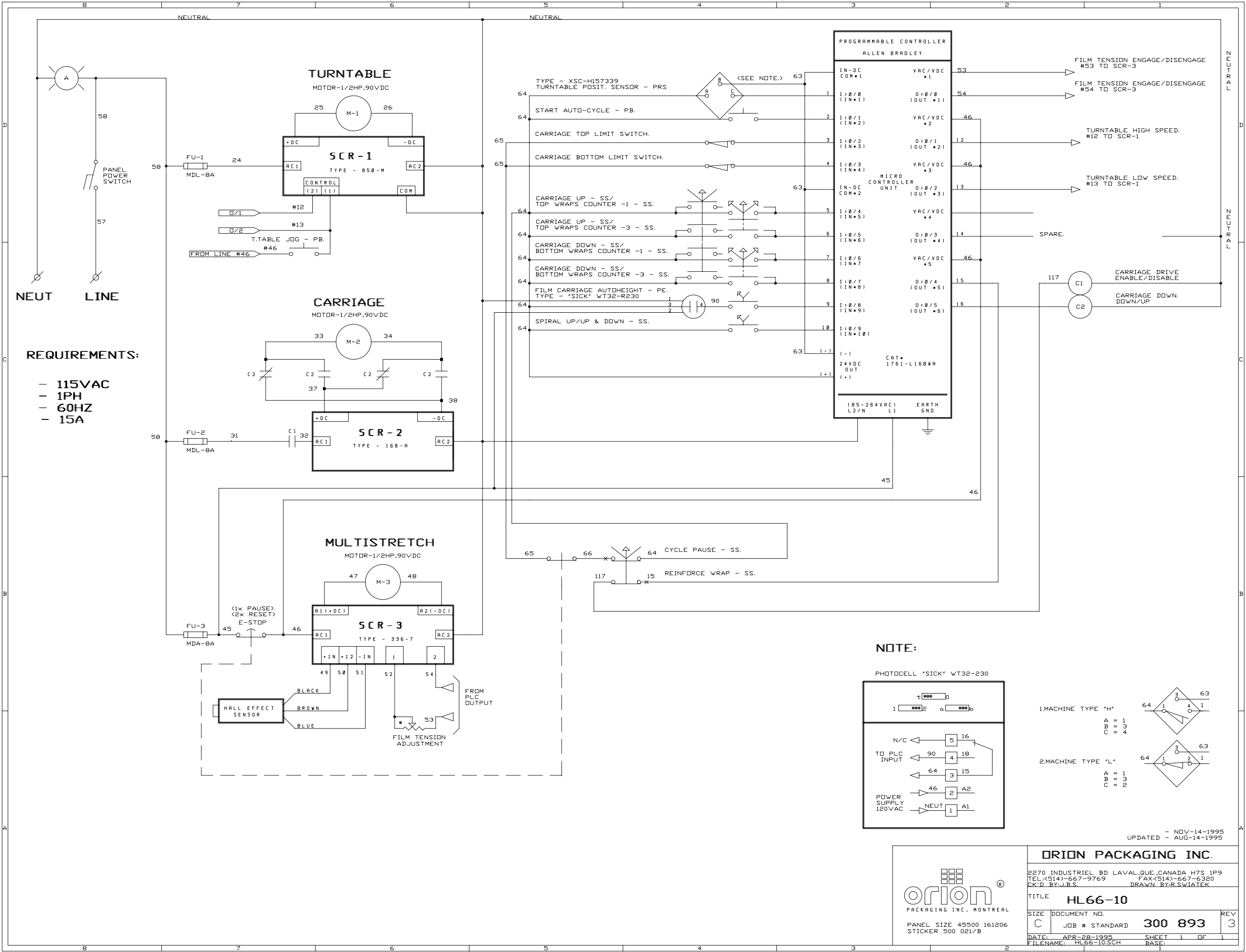

REQUIREMENTS:

- 115VAC
- 1PH
- 60HZ
- 15A

NOTE:

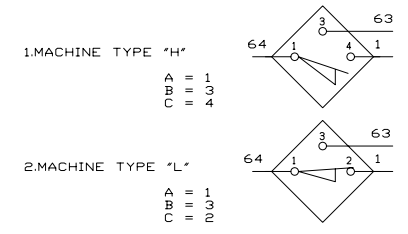
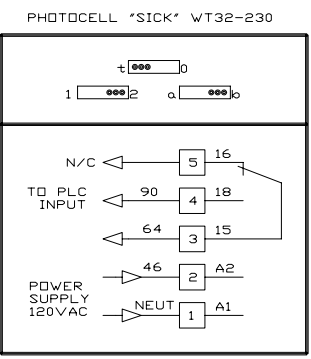

PACKAGING INC. MONTREAL

PANEL SIZE 45500 161206
STICKER 500 021/B

ORION PACKAGING INC.

2270 INDUSTRIEL BD LAVAL, QUE., CANADA H7S 1P9
TEL: (514)-667-9769 FAX: (514)-667-6320
CK'D BY: J.B.S. DRAWN BY: R.SWIATEK

TITLE: **HL66-10**

SIZE	DOCUMENT NO.	REV
C	JOB # STANDARD	3
DATE:	SHEET	OF
APR-28-1995	1	1
FILENAME: HL66-10.SCH	BASE:	

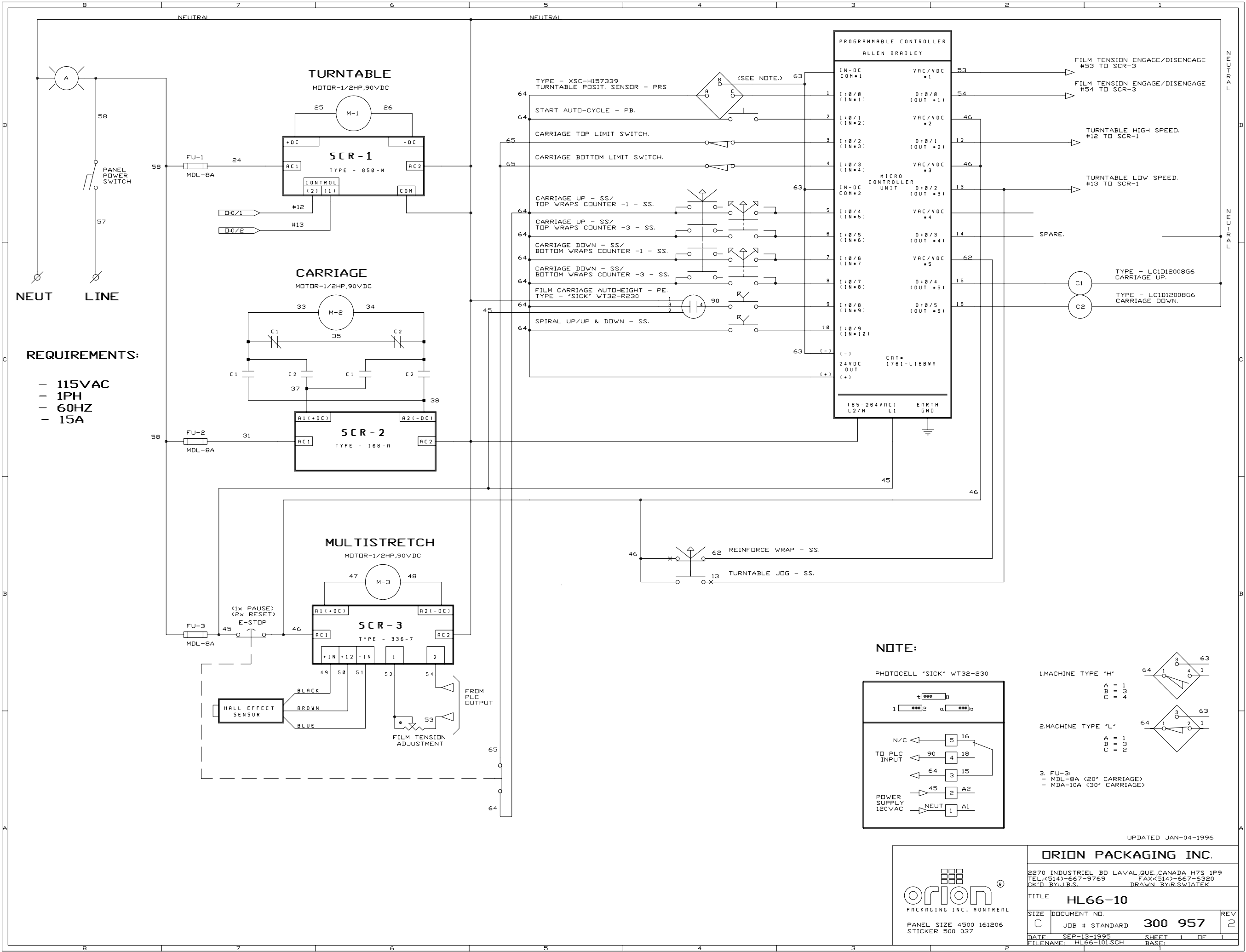

REQUIREMENTS:

- 115VAC
- 1PH
- 60HZ
- 15A

NOTE:

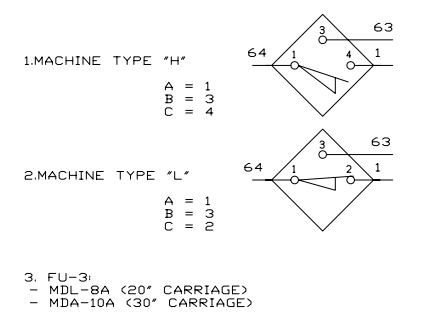
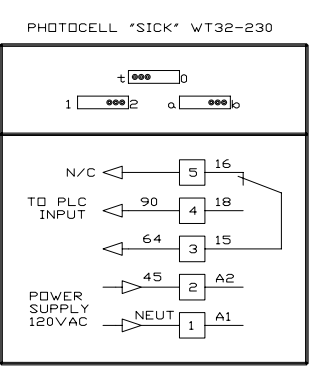

UPDATED JAN-04-1996

PACKAGING INC. MONTREAL

PANEL SIZE 4500 161206
STICKER 500 037

ORION PACKAGING INC.

2270 INDUSTRIEL BD LAVAL, QUE., CANADA H7S 1P9
TEL: (514)-667-9769 FAX: (514)-667-6320
CK'D BY: J.B.S. DRAWN BY: R.SWIATEK

TITLE: **HL66-10**

SIZE	DOCUMENT NO.	REV
C	JOB # STANDARD	300 957 2
DATE:	SEP-13-1995	SHEET 1 OF 1
FILENAME:	HL66-101.SCH	BASE:

MULTISTRETCH TROUBLE SHOOTING GUIDE 1

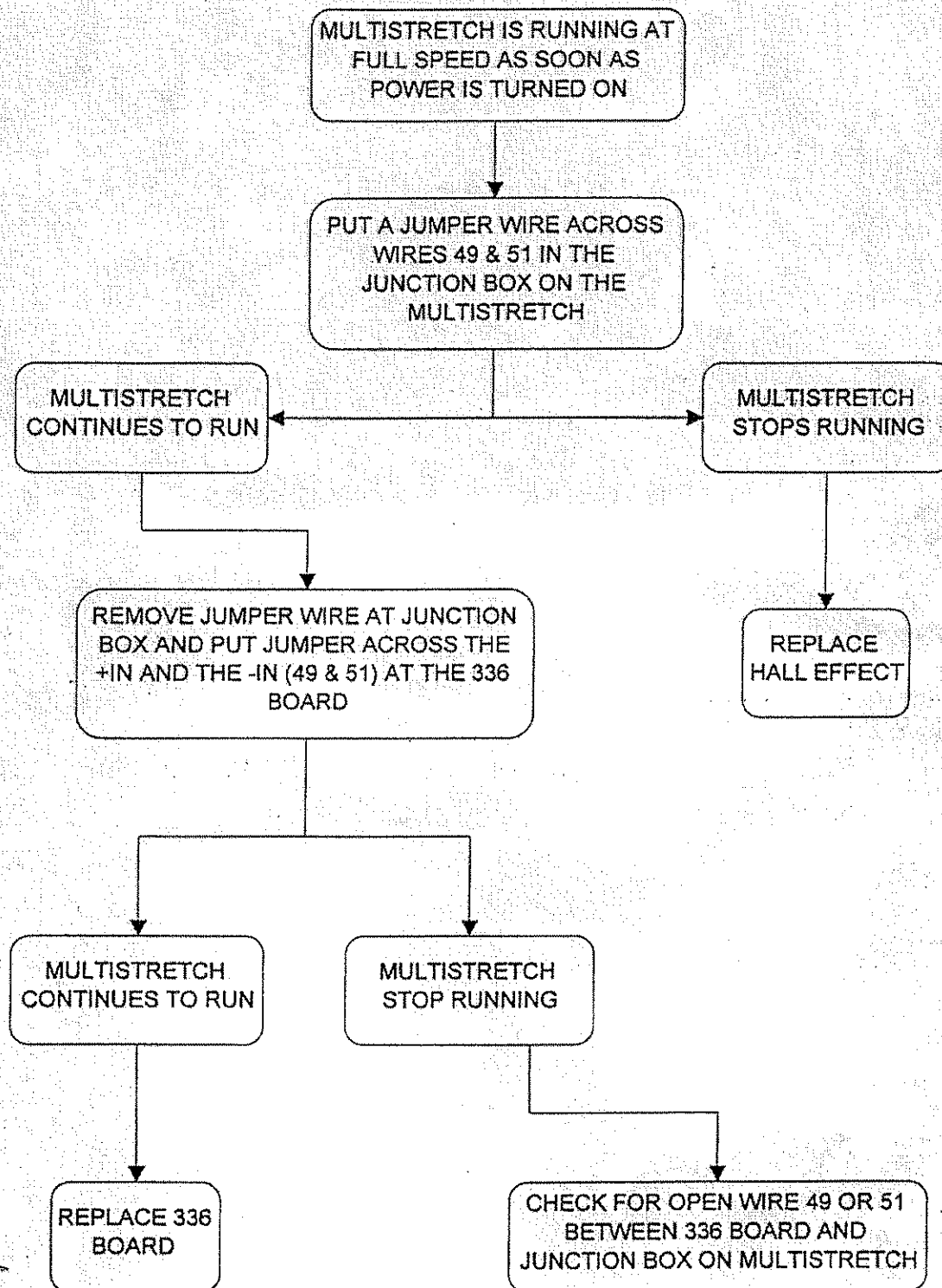

MULTISTRETCH TROUBLE SHOOTING GUIDE 2

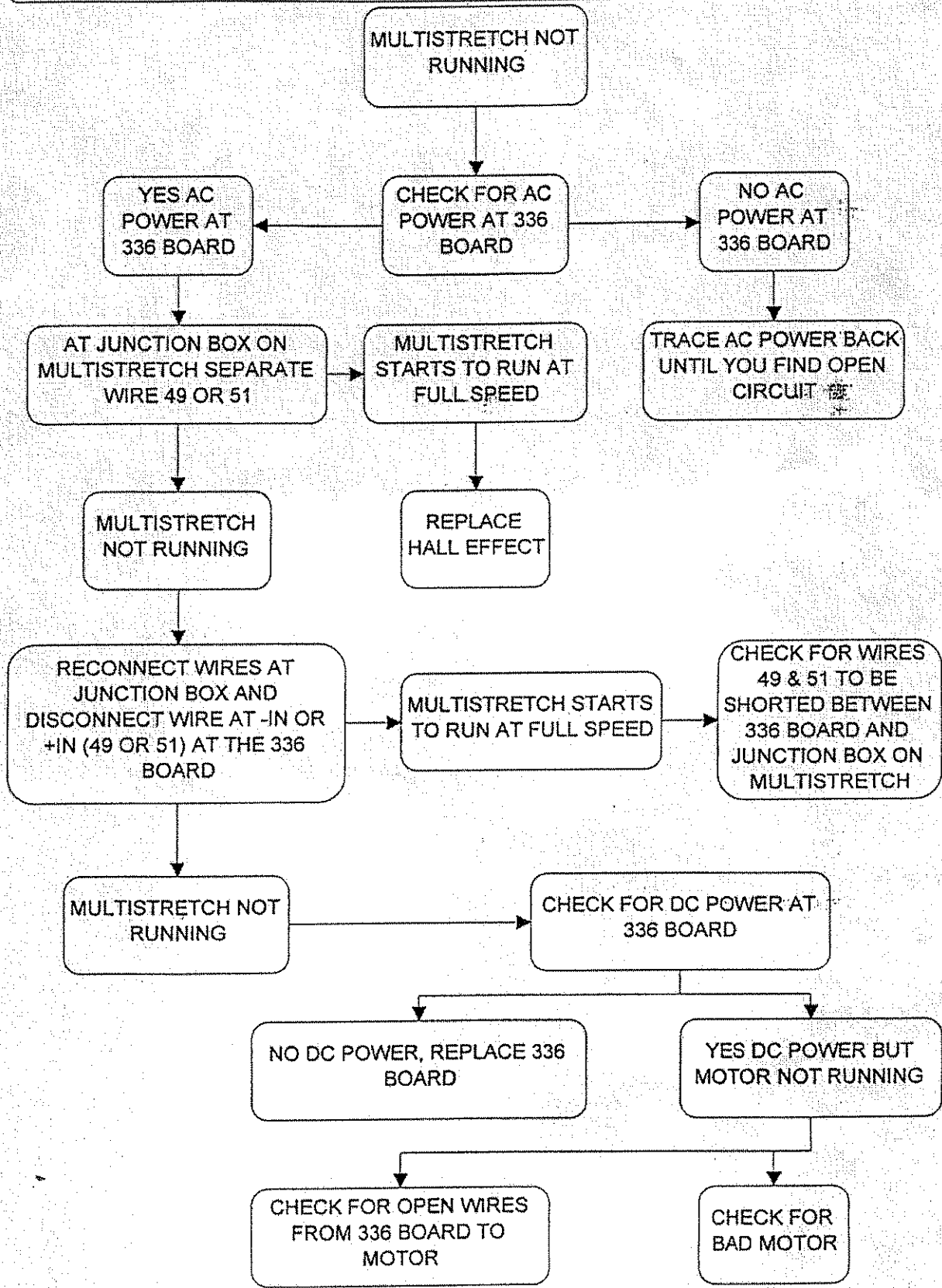

1 BASIC CARRIAGE RAISE / LOWER TROUBLE SHOOTING GUIDE

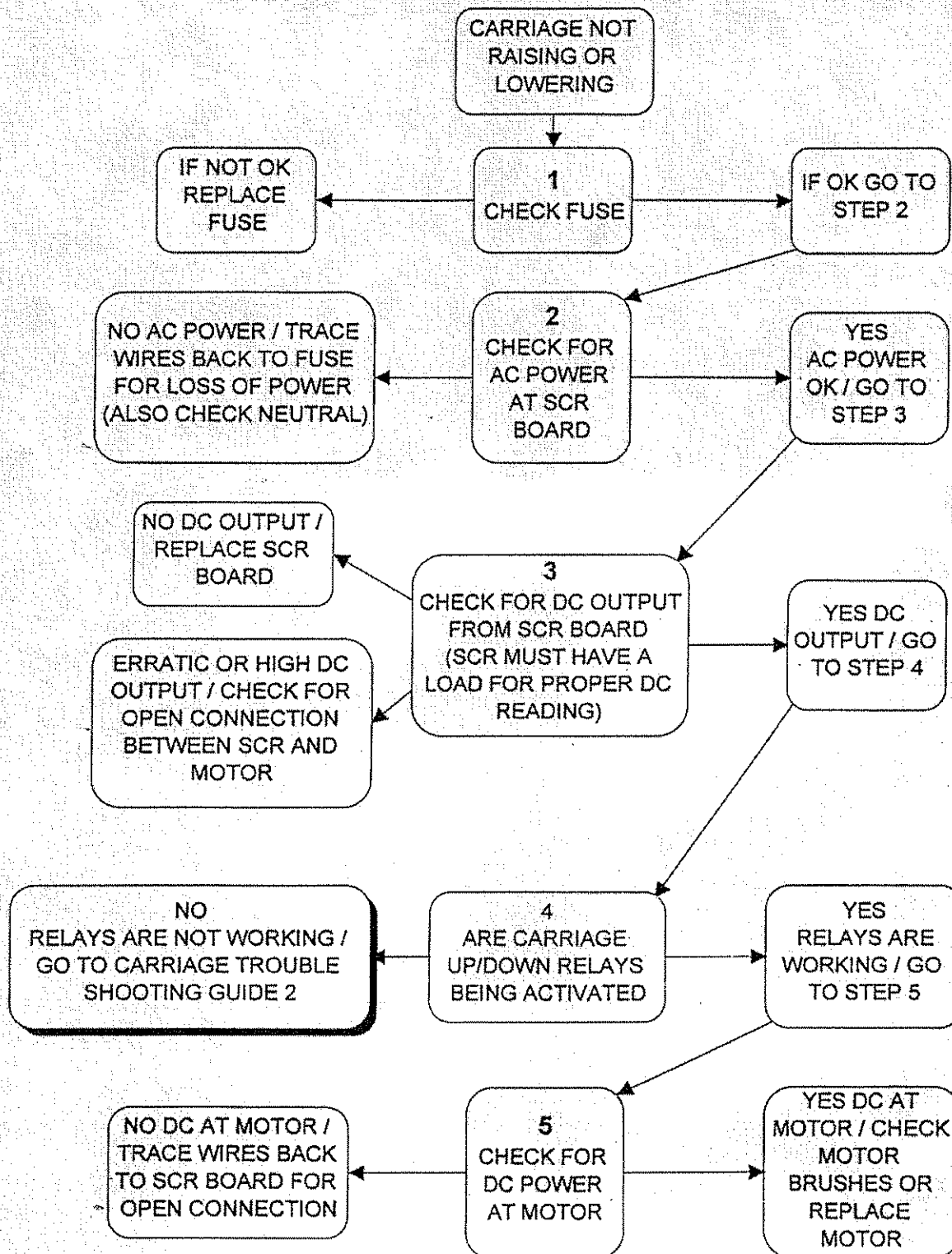

2 BASIC CARRIAGE RAISE / LOWER TROUBLE SHOOTING GUIDE

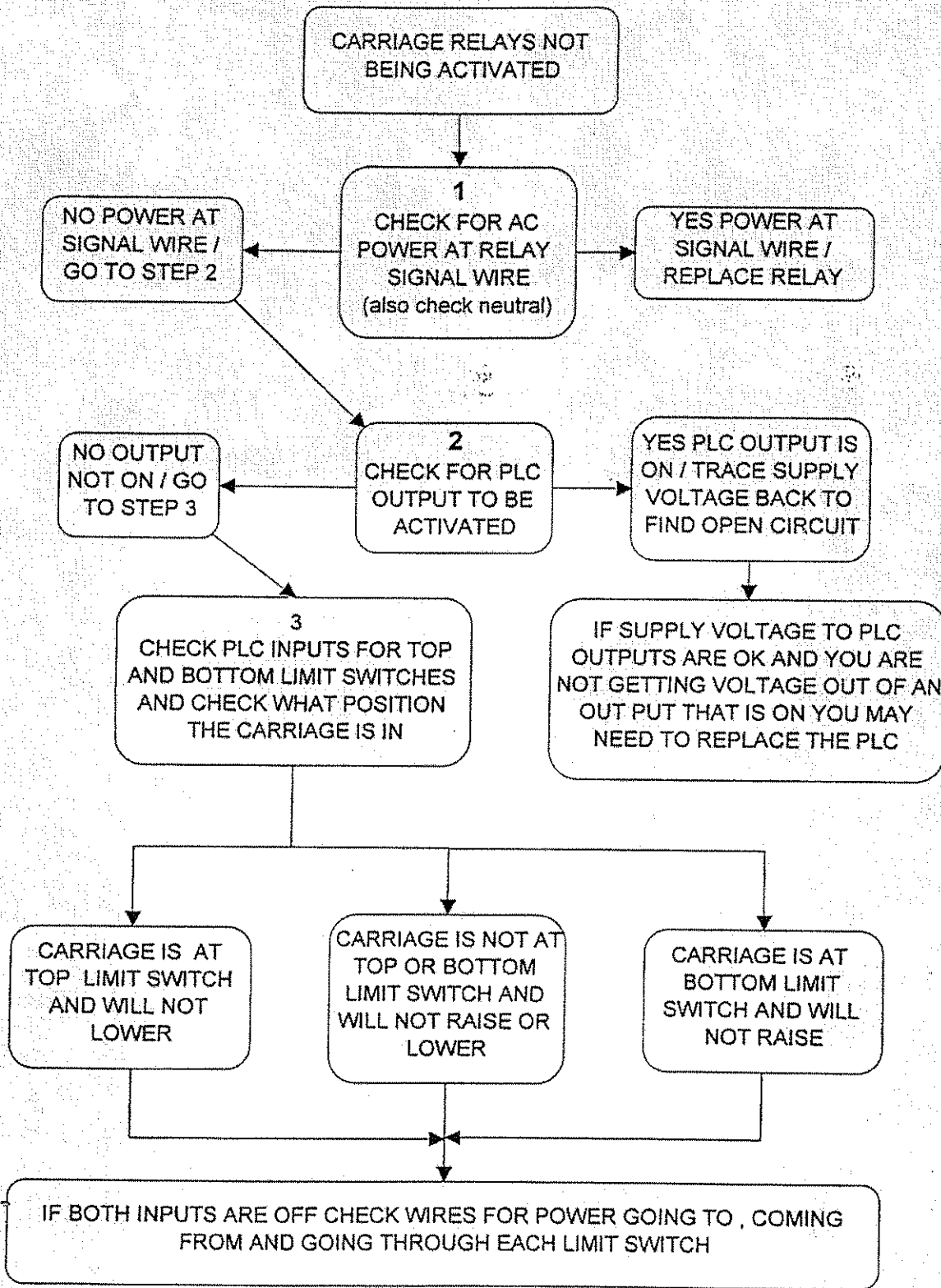

BASIC TURNTABLE TROUBLE SHOOTING GUIDE

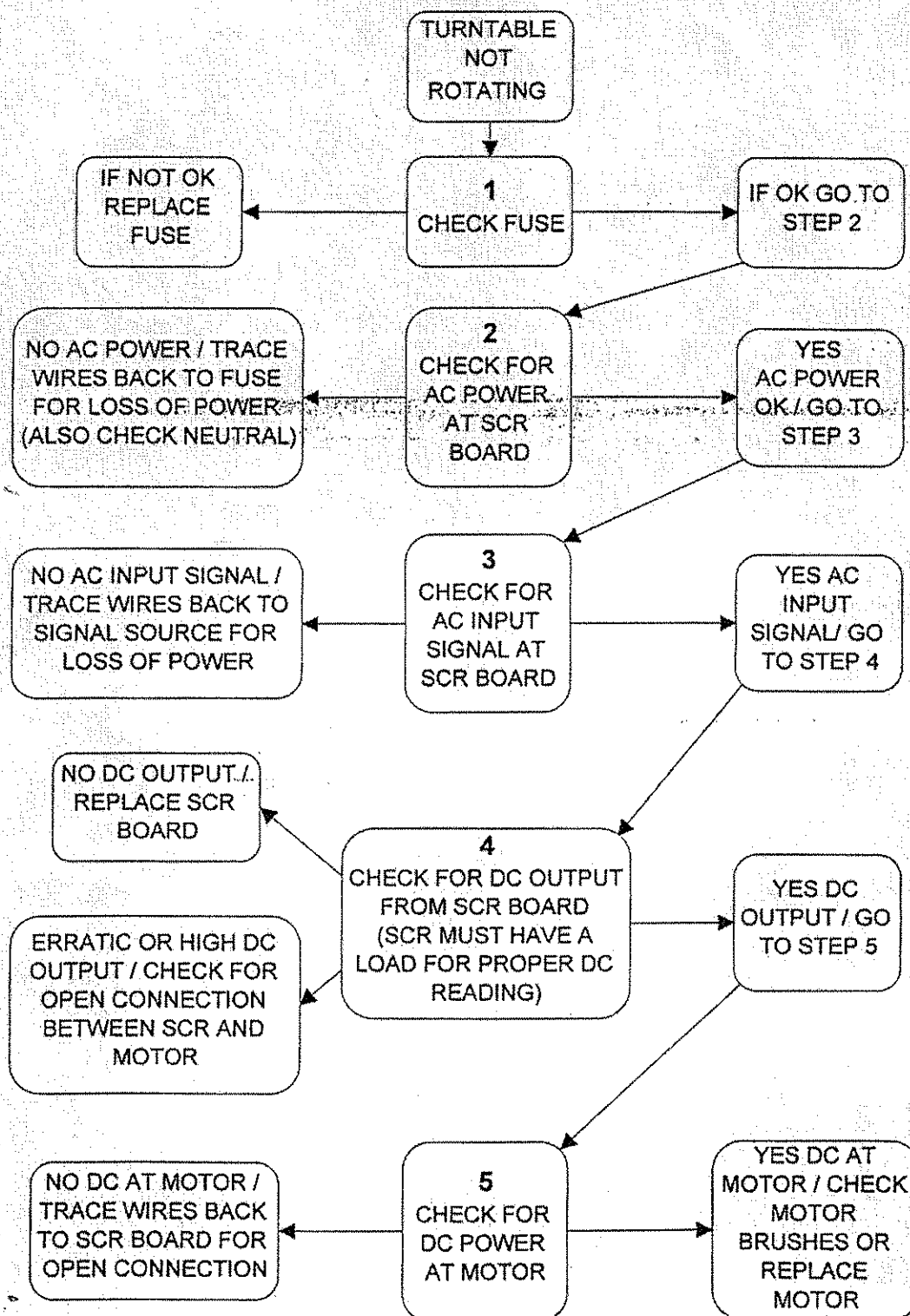

- IF TURNTABLE RUNS AS SOON AS POWER IS TURNED ON THE MOTOR MAY HAVE AN INTERNAL SHORT TO GROUND.